

BJC-6500

SERVICE MANUAL

REVISION 0

Canon

OCT. 1999

QY8-1368-000

1099 SE 0.30-0

BJC-6500

SERVICE MANUAL

Canon

Target Readers

This manual is published by Canon Inc. for qualified persons and contains the necessary technical information for technical theory, installation, maintenance, and repair of products. This manual covers all localities where the products are sold. For this reason, it may contain information that does not apply to your locality.

Revisions

This manual may include technical inaccuracies or typographical errors due to improvements or changes in the products. When amendments are made to the content of this manual, Canon will issue technical information as the need arises. In the event of major alterations to the content of this manual over a long or short period, Canon will publish a revised version of the manual.

The following paragraphs do not apply to any countries where such provisions are inconsistent with local law.

Trademarks

The product names and company names appearing in this manual are the registered trademarks or trademarks of the individual companies.

Copyright

This manual is copyrighted and all rights reserved. Under the copyright laws, this manual may not be copied, reproduced, or translated into other languages, in whole or in part, without the express written consent of Canon Inc. except in the case of internal business use.

Copyright © 1999 by Canon Inc.

CANON INC.

BJ Products Quality Support Dept.

16-1, Shimonoge 3-chome, Takatsu-ku, Kawasaki-shi, Kanagawa 213, Japan

This manual was produced on an Apple Macintosh™ Power Mac 9600/233 personal computer and Apple LaserWriter™ II NTX-J laser beam printer; final pages were printed on Varityper™ 5300 with 4000-J RIP. A Canon mo-5001S Magneto-Optical Storage Subsystem with mo-502M Magneto-Optical Storage Disk Cartridge and mo-IF2 interface kit were used for storing large volumes of page layout and graphic data for this manual.

All graphics were produced with MACROMEDIA FREEHAND™ 7.0J.

All documents and all page layouts were created with QuarkXPress™ 3.3J.

I. ABOUT THIS MANUAL

This manual is divided into five parts containing the information required for servicing the BJC-6500 printer.

Part 1: PRODUCT SPECIFICATIONS

This part outlines the product and its specifications.

Part 2: MAINTENANCE

This part explains maintenance of the unit. It includes precautions and details for disassembly and assembly, and adjustments required when assembling.

Part 3: OPERATION

This part explains how to operate the unit properly, and how to use the service mode.

Part 4: TROUBLESHOOTING

This part explains how to resolve problems of the unit, and contains information on how to locate and replace serviceable units and parts. It is divided into two sections: "Troubleshooting by Errors" and "Troubleshooting by Symptoms."

Part 5: REFERENCE

This part outlines the unit operation giving technical information on hardware, and contains block diagrams, pin assignments, and wiring/circuit diagrams.



REF.

This manual does not contain complete information required for disassembling and assembling the BJC-6500 printer. Please also refer to the separate Parts Catalog.

PRODUCT
SPECIFICATIONS

MAINTENANCE

OPERATION

TROUBLE
SHOOTING

REFERENCE

II. TABLE OF CONTENTS

	<i>Part 1: PRODUCT SPECIFICATIONS</i>
Page	
1 - 1	1. PRODUCT OUTLINE
1 - 1	1.1 Product Outline
1 - 2	1.2 Features
1 - 3	2. SPECIFICATIONS
1 - 3	2.1 General Specifications
1 - 3	2.1.1 Printer specifications
1 - 4	2.1.2 Product life
1 - 4	2.2 Paper Specifications
1 - 4	2.2.1 Paper sizes
1 - 4	2.2.2 Paper type/settings
1 - 4	2.2.3 Printable area
1 - 5	2.3 BJ Cartridge Specifications
1 - 6	2.4 Scanner Cartridge Specifications
1 - 6	2.4.1 Scannable area
1 - 7	2.5 Interface Specifications
1 - 7	2.5.1 Parallel interface
1 - 7	2.5.2 Serial interface
1 - 8	2.6 Printer Driver/Scanner Driver Types
1 - 9	3. PRINTER PACKING
1 - 10	4. NAMES OF PARTS AND THEIR FUNCTIONS
1 - 11	5. PRODUCT CODE LIST
	 <i>Part 2: MAINTENANCE</i>
2 - 1	1. PERIODICAL REPLACEMENT/MAINTENANCE
2 - 1	1.1 Parts for Periodical Replacement
2 - 1	1.2 List of Periodical Maintenance
2 - 2	2. DISASSEMBLY AND REASSEMBLY
2 - 2	2.1 List of Tools
2 - 3	2.2 Precautions for Disassembly and Reassembly
2 - 3	2.2.1 Precautions for ink stains (ink paths/ink mist)
2 - 4	2.2.2 Precautions for damage due to static electricity
2 - 5	2.2.3 Precautions for transporting the printer
2 - 5	2.2.4 Precautions on spur tip deformation
2 - 6	2.3 Disassembling and Reassembling the Printer
2 - 6	2.3.1 Unlocking the carriage
2 - 6	2.3.2 Reinstalling tap screws
2 - 7	2.3.3 Removing the printer unit
2 - 8	2.3.4 Removing the ASF unit
2 - 8	2.3.5 Removing the adjustable bushings supporting the carriage shaft
2 - 9	2.3.6 Paper feed gear handling
2 - 9	2.3.7 Spur holder assembly installation
2 - 10	2.3.8 Grease application points
2 - 11	2.4 Adjustment/Setting Procedures
2 - 11	2.4.1 Adjustments (item, adjustment points, tools)
2 - 12	2.4.2 When to perform print head position adjustment
2 - 13	2.4.3 When to reset the EEPROM
2 - 13	2.4.4 How and when to adjust the carriage belt tension
2 - 14	2.4.5 How to adjust the ASF gear position
2 - 16	2.4.6 How to adjust the head gap
2 - 18	3. CONFIRMATION OF OPERATION
2 - 18	3.1 Confirmation Methods

2 -19	4. TRANSPORTING THE PRINTER
2 -19	4.1 Procedures for Packing the Printer for Transportation

	Part 3: OPERATION
	1. FUNCTIONS RELATED TO PRINTER OPERATION
3 - 1	1.1 Status Display
3 - 1	1.1.1 Status display via the indicator
3 - 2	1.1.2 Status display via the BJ status monitor
3 - 4	1.2 Operations from the Computer
3 - 5	1.2.1 Function settings using the printer driver
3 - 5	1.3 Operations from the Printer
3 - 6	1.3.1 Cleaning
3 - 6	1.3.2 Nozzle check pattern printing
3 - 8	2. SERVICE FUNCTIONS
3 - 8	2.1 Service Mode Operations
3 - 9	2.2 Printing the Service/Factory Test Print
3 -10	2.3 Printing the EEPROM Information
3 -11	2.4 Resetting the EEPROM
3 -11	2.5 Setting the Model
3 -11	2.6 Checking the Presence of Ink
3 -11	2.7 Conducting the Print Head Position Adjustment
3 -11	2.8 Powering Off and Locking the Carriage

	Part 4: TROUBLESHOOTING
	1. TROUBLESHOOTING BY DISPLAYED ERRORS
4 - 1	1.1 Initial Flowchart
4 - 1	1.2 Error Indications (Indicator, Beeper, Error Code)
4 - 5	1.3 Troubleshooting by Errors
4 - 6	2. TROUBLESHOOTING BY SYMPTOMS
4 -19	2.1 Troubleshooting by Symptoms

Page	<i>Part 5: REFERENCE</i>
5 - 1	1. TECHNICAL REFERENCE
5 - 1	1.1 Functions of the Paper Feed Unit
5 - 2	1.2 Construction of the Paper Feed Unit
5 - 3	1.3 Form Alignment Function
5 - 4	1.4 Transmission Gear Unit
5 - 5	1.5 Detection with Sensors
5 - 5	1.6 BJ Cartridge Identification
5 - 6	2. CONNECTOR POSITIONS AND PIN ASSIGNMENT
5 - 6	2.1 Control Board
5 -11	2.2 Carriage Board
5 -14	2.3 BJ Cartridge
5 -15	2.4 Scanner Cartridge (Optional)
5 -16	2.5 AC Adapter
5 -16	2.6 DC Power Supply Cable
5 -17	2.7 Carriage Motor
5 -17	2.8 Paper Feed Motor
5 -17	2.9 Paper End Sensor
5 -18	2.10 Ink Sensor
5 -18	2.11 Print Position Sensor
5 -18	2.12 Pump Sensor
5 -19	3. INSTALLATION
5 -19	3.1 Installation
5 -19	3.1.1 Installation location
5 -19	3.2 Installation Procedures
5 -19	3.2.1 Connecting the interface cable
5 -19	3.2.2 Connecting the power supply
5 -20	4. MISCELLANEOUS
5 -20	4.1 Similarities and Differences to the BJC-6100

III. ILLUSTRATION INDEX

Page	<i>Part 1: PRODUCT SPECIFICATIONS</i>	
1 - 1	Figure 1- 1	Printer Appearance
1 - 5	Figure 1- 2	Printable Area
1 - 6	Figure 1- 3	Scannable Area
1 - 9	Figure 1- 4	Packaging
1 -10	Figure 1- 5	Names of Parts and Their Functions
	 <i>Part 2: MAINTENANCE</i>	
2 - 3	Figure 2- 1	Ink Paths
2 - 4	Figure 2- 2	Ink Mist
2 - 5	Figure 2- 3	Capping Position
2 - 5	Figure 2- 4	Spur Unit
2 - 6	Figure 2- 5	Unlocking the Carriage
2 - 7	Figure 2- 6	Removing the Printer Unit
2 - 8	Figure 2- 7	Removing the ASF Unit
2 - 8	Figure 2- 8	Adjustable Bushings Supporting the Carriage Shaft
2 - 9	Figure 2- 9	Paper Feed Gears
2 - 9	Figure 2- 10	Spur Holder Ass'y Installation
2 -10	Figure 2- 11	Grease Points
2 -12	Figure 2- 12	Print Position Adjustment Pattern
2 -13	Figure 2- 13	Carriage Belt Tension Adjustment
2 -14	Figure 2- 14	ASF Gear Position Adjustment 1
2 -15	Figure 2- 15	ASF Gear Position Adjustment 2
2 -16	Figure 2- 16	Head Gap Adjustment 1
2 -17	Figure 2- 17	Head Gap Adjustment 2
	 <i>Part 3: OPERATIONS</i>	
3 - 1	Figure 3- 1	Operation Panel
3 - 4	Figure 3- 2	BJ Status Monitor (Sample)
3 - 5	Figure 3- 3	Printer Driver Utility (Sample)
3 - 7	Figure 3- 4	Nozzle Check Pattern Print (Sample for Black/Color Cartridge)
3 - 9	Figure 3- 5	Service/Factory Test Print
3 -10	Figure 3- 6	EEPROM Information Print (Sample)
3 -11	Figure 3- 7	Checking for Presence of Ink

Part 5: REFERENCE

5 - 1	Figure 5- 1	Paper Feed Path
5 - 2	Figure 5- 2	Paper Pick-up Unit
5 - 3	Figure 5- 3	Form Alignment Function
5 - 3	Figure 5- 4	Form Alignment Function On/Off
5 - 4	Figure 5- 5	Drive Switching Unit
5 - 4	Figure 5- 6	Operation of the Drive Switching Unit
5 - 5	Figure 5- 7	Sensor Positions
5 - 6	Figure 5- 8	Control Board
5 - 6	Figure 5- 9	Block Diagram
5 -11	Figure 5- 10	Carriage Board
5 -14	Figure 5- 11	BJ Cartridge
5 -15	Figure 5- 12	Scanner Cartridge
5 -16	Figure 5- 13	AC Adapter
5 -16	Figure 5- 14	DC power Supply Cable
5 -17	Figure 5- 15	Carriage Motor
5 -17	Figure 5- 16	Paper Feed Motor
5 -17	Figure 5- 17	Paper End Sensor
5 -18	Figure 5- 18	Ink Sensor
5 -18	Figure 5- 19	Print Position Sensor
5 -18	Figure 5- 20	Pump Sensor
5 -19	Figure 5- 21	Printer Dimensions

IV. TABLE INDEX

Page	<i>Part 3: OPERATION</i>
3 - 2	TABLE 3- 1 STATUS DISPLAY VIA THE INDICATOR
	<i>Part 4: TROUBLESHOOTING</i>
4 - 5	TABLE 4- 1 ERROR INDICATIONS

Part 1

PRODUCT SPECIFICATIONS

Page	
1 - 1	1. PRODUCT OUTLINE
1 - 1	1.1 Product Outline
1 - 2	1.2 Features
1 - 3	2. SPECIFICATIONS
1 - 3	2.1 General Specifications
1 - 4	2.2 Paper Specifications
1 - 4	2.3 BJ Cartridge Specifications
1 - 6	2.4 Scanner Cartridge
1 - 7	2.5 Interface Specifications
1 - 8	2.6 Printer Driver Types
1 - 9	3. PRINTER PACKING
1 -10	4. NAMES OF PARTS AND THEIR FUNCTIONS
1 -11	5. PRODUCT CODE LIST



1. PRODUCT OUTLINE

1.1 Product Outline

This printer is a BJC-6100 leveraged printer, attaining high performance in a business-use setting. It supports on A3 size paper, and utilizes the BJC-6100 printer engine to achieve high-speed/high-quality printing.

PRODUCT SPECIFICATIONS

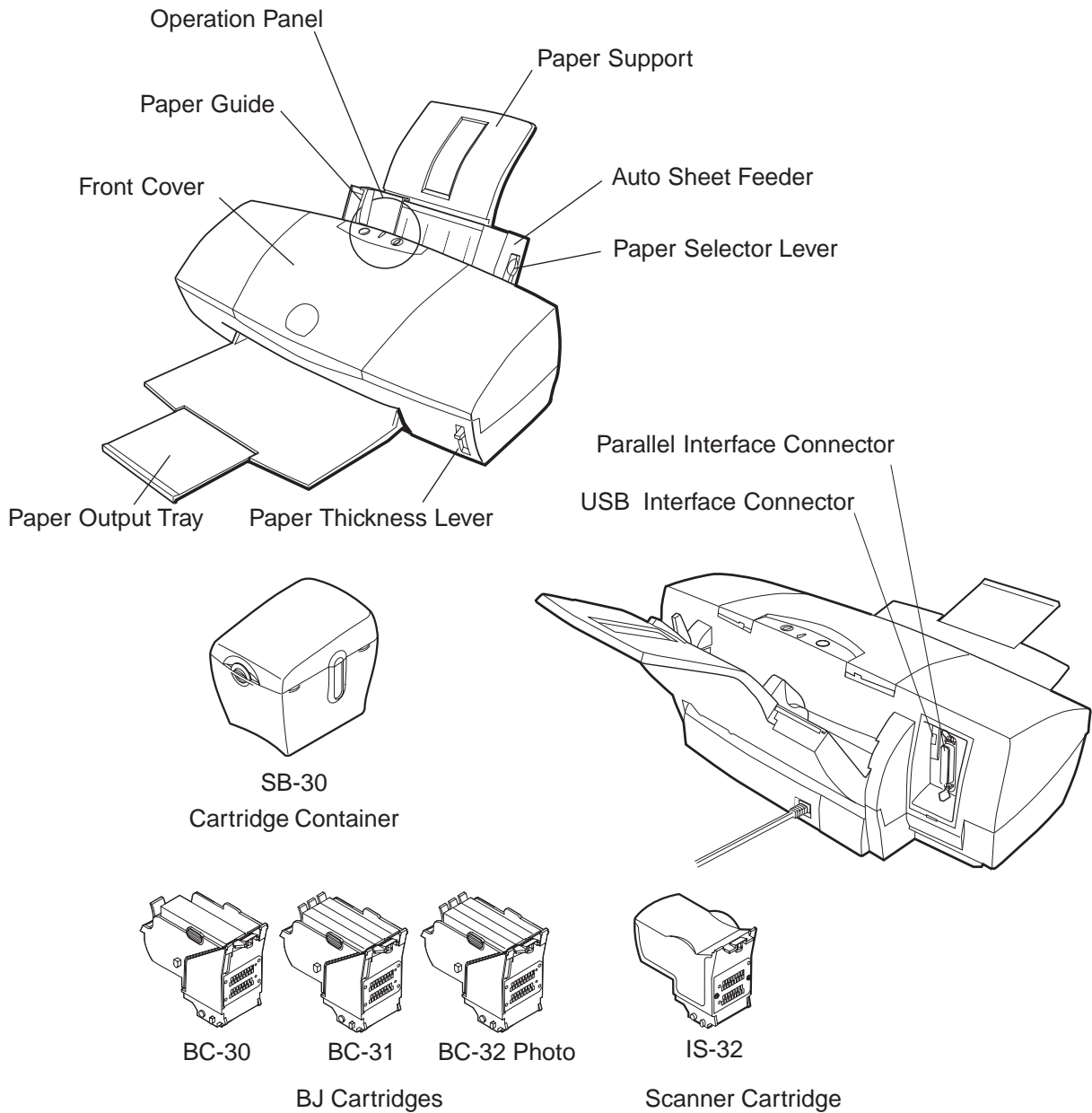

Figure 1-1 Printer Appearance

1.2 Features

This printer differs from the BJC-6100 in the following ways:

1. Supported paper size has increased from A4 to A3
2. Automatic Form Alignment Function (improves skew control) n/a→built-in
For details, refer to *Part 5: REFERENCE* (Page 5-20).

Other functions remain commonly shared with the BJC-6100, as follows.

- Laser-printer quality using pigment black ink
- Dual-cartridge system
High quality printing at high speed from a combination of the Black and Color cartridges or the Color and Photo cartridges

Black BJ cartridge: Drop modulation, replaceable ink tank (pigment black), 160 nozzle head
Color BJ cartridge: Drop modulation, individually replaceable ink tanks (yellow, magenta and cyan), 144 in-line nozzle head (48 nozzles for each of three colors)
Photo BJ cartridge: Drop modulation, individually replaceable ink tanks (dye black, photo-magenta and photo-cyan), 144 in-line nozzle head (48 nozzles for each of three colors)
- Individually replaceable ink tanks for high cost performance
Black ink tanks: Pigment black ink tank
Color ink tanks: Yellow, magenta, and cyan ink tanks
Photo ink tanks: Dye black, magenta, and cyan ink tanks
Ink-out detection, and translucent ink tanks for easier ink level checking
- High speed printing (9.0 PPM black printing or 6.0 PPM color printing in HS mode)
1440 x 720 dpi high resolution printing
- Automatic printing position adjustment
Ensures accurate printing position regardless of cartridges being used or carriage movement direction
- Supports a wide variety of print media
- Blue Angel compliant
- USB and IEEE 1284 compatible 8-bit parallel interfaces.
- Optional scanner cartridge with maximum readout resolution of 720×720 dpi also available.

2. SPECIFICATIONS

2.1 General Specifications

2.1.1 Printer specifications

Type	Desktop serial color bubble-jet printer			
Paper feeding method	Automatic sheet feeder (no manual feed)			
Resolution	1440dpi x 720dpi (maximum resolution)			
Throughput		HS	HQ	Fine
	BC-30 + BC-31			
	Black Text (PC Magazine)	8.0ppm	6.5ppm	...
	Black (New Black)	9ppm	7.1ppm	...
	Color (New Color)	6ppm	4.6ppm	...
	BC-32Photo + BC-31			
	Photo	0.17ppm
Printing direction	HS mode:	Bi-directional		
	HQ mode: (360dpi x 360dpi):	Bi-directional		
	Fine mode (720dpi x 720dpi):	Uni-directional		
	Fine mode (1440dpi x 720dpi):	Uni-directional		
Printing width	289.6mm			
Line feed speed	HQ, HS mode 4 "/S			
Interface	IEEE 1284-compatible 8-bit parallel interface (Compatible/nibble/ECP), USB			
Automatic sheet feeder capacity				
Plain paper:	10 mm max. stacking height (about 100 sheets of 64 g/m ² paper)			
High-resolution paper:	10 mm max. stacking height (about 80 sheets of High-resolution paper)			
Detection functions				
Cover open:	Yes	Paper detection:	Yes	
BJ cartridge installed:	Yes	Ink-out :	Yes	
Print position detection:	Yes	Waste ink amount:	Yes	
BJ cartridge identification:	Yes	Paper width detection:	No	
Pick-up roller position:	Yes			
Acoustic noise during operation				
Approx. 48 dB / HQ mode (Sound pressure level: compliant with ISO9296)				
Environmental conditions				
Operating:	5 to 35°C (41 to 95° F), 10 to 90% RH (no condensation)			
Storage:	0 to 35°C (32 to 95° F), 5 to 95% RH (no condensation)			
Power consumption	Operating	Standby		
	Approx. 30 W max.	Approx. 3 W max.		
External dimensions	574 mm W x 328mm D x 205 mm H			
Weight	6.8 kg, including BJ cartridges			
Certification				
Electromagnetic radiance:	VDE0871 CLASS B, CISPR PUBLICATION '22			
Electrical safety:	Energy Star, IEC950, AS, GS, FIMCO, SEMCO, SISIR, Electrical Safety Regulations of Korea, CCIB (China), CE Mark, EI, MEMCO			
Environmental regulations:	Energy Star, Blue Angel			
Serial No. location	On the printer frame (visible when the front cover is open)			

2.1.2 Product life

The print quality can be assured during the product life given below, if the specified maintenance is conducted.

- (1) Monochrome printing 60,000 sheets (1500 ANK character pattern) OR,
- (2) Color printing 12,000 sheets (7.5% duty per color pattern) OR,
- (3) 5 years (from the start of use), whichever comes first

2.2 Paper Specifications

2.2.1 Paper sizes

- (1) Paper size
A5, A4, A3 (V), B5, B4 (V), Letter, Legal, A4+, Letter+, Envelope Com #10/DL, Other (100 x 100 ~ 297 x 584mm)
- (2) Paper weight
Automatic Sheet Feeder: 64 ~ 105 g/m²

2.2.2 Paper type/settings

Paper Type		Stacked in the ASF	Paper selector lever position	Paper thickness lever position
Plain paper (64 g/m ²)		Approx. 10mm or less (Approx. 100 sheets)	Back	Up
Color BJ paper	LC-301	Approx. 10mm or less	Back	Up
High-resolution paper	HR-101	Approx. 10mm or less (Approx. 80 sheets)	Back	Up
Glossy photo paper	GP-301	1 sheet (portrait)	Forward	Up
Glossy photo film	HG-201	1 sheet	Forward	Up
OHP film	CF-102	30 sheets or less	Back	Up
Back print film	BF-102	10 sheets or less	Back	Up
BJ cloth	FS-101	1 sheet	Forward	Down
Banner paper	BP-101	1 sheet	Forward	Down
T-shirt transfer	TR-201	1 sheet	Forward	Down
Glossy photo card	FM-101	1 sheet	Forward	Up
Envelope	Com. #10 DL	10 sheets or less (portrait)	Forward	Down
Thick paper		1 sheet	Forward	Down



If the Paper Selector Lever/Paper Thickness Lever are incorrectly set for the paper used, paper feeding or printing problems may occur. For details on the lever positions, refer to *Part 1: PRODUCT SPECIFICATIONS* (Page 1-10).

2.2.3 Printable area

Refer to Figure 1-2 Printable Area.

2.3 BJ Cartridge Specifications

	Black BJ cartridge	Color BJ cartridge	Photo BJ cartridge
Construction:	Separate ink tank	Separate ink tank	Separate ink tank
Print head:	160 nozzles, in-line	144 nozzles, in-line (48 nozzles x 3)	144 nozzles in-line (48 nozzles x 3)
Inks:	Pigment black	C, M, Y	Photo-Bk, Photo-C, Photo-M
Cartridge life:	Approx. 5000 pages*	Approx. 3000 pages**	Approx. 3000 pages**
Ink tank:	Black	C, M, Y	Photo-Bk, Photo-C, Photo-M
Ink tank life:	Approx. 500 pages*	Approx. 280 pages**	Approx. 280 pages**
Cartridge weight: (w/o ink tank)	Approx. 60 g	Approx. 60 g	Approx. 60 g

PRODUCT SPECIFICATIONS

- * **Monochrome printing** (1500-character, HQ mode)
- ** **Color printing** (7.5% duty, HQ mode)

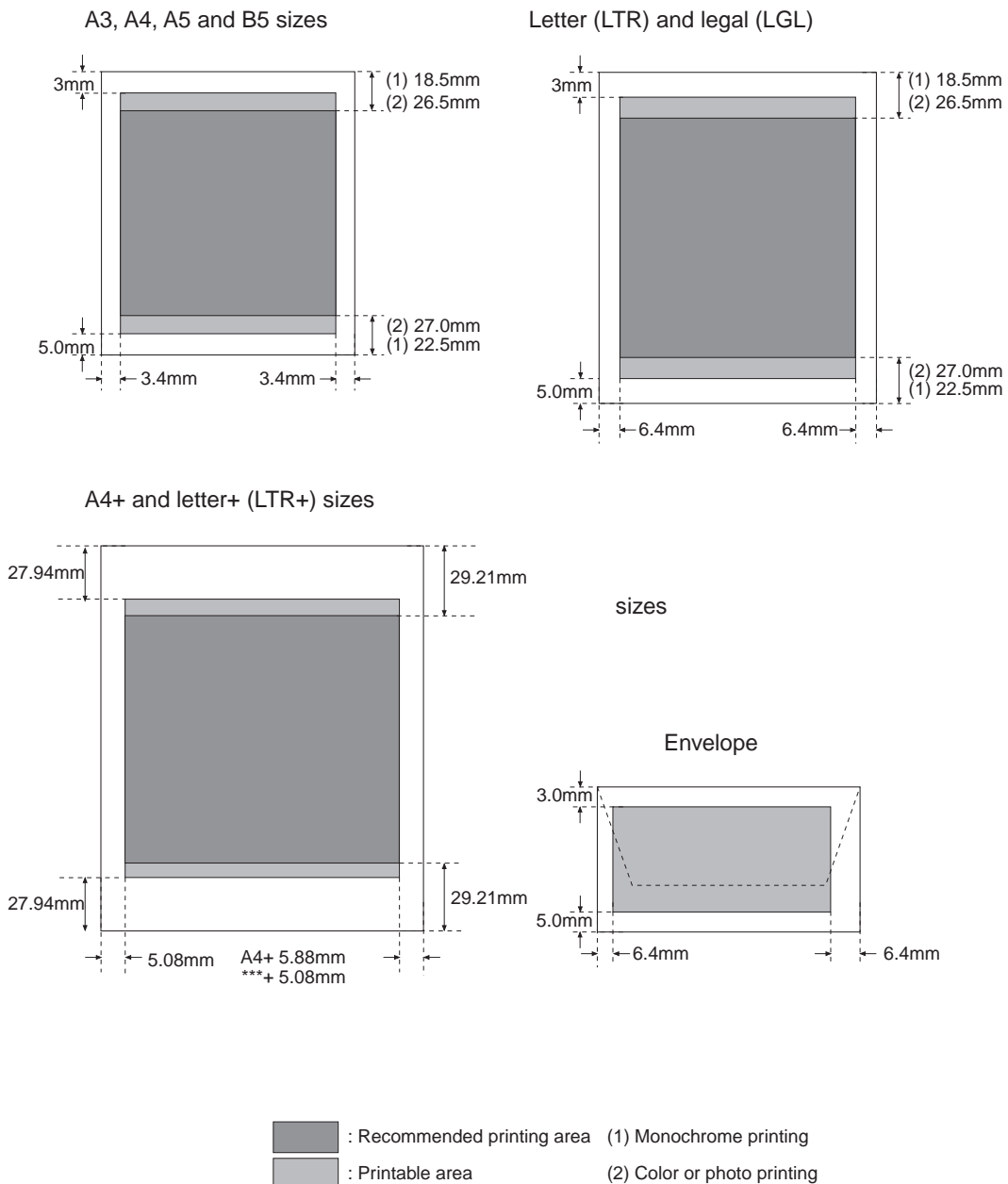

Figure 1-2 Printable Area

2.4 Scanner Cartridge Specifications

Name	IS-32
Type	Cartridge replacement type color scanner
Resolution (dpi)	90×90, 180×180, 300×360, 360×360, 720×720
Image sensor	Single-line, 256 pixel CCD
Light source	RGB (R; Red, G; Green, B; Blue)
Scanning method/direction	Sequential RGB light source switching method
Document feeding method	Place the document into the scanning holder and feed it through ASF
Gradation	10 bit input, 8 bit output
Input voltage	5/12 V
Power consumption	Approx 30 W (90 dpi, monochrome), SW (stand by)
Interface	ECP/Nibble
External dimensions	Approx. 41 mm W × 90 mm D × 77 mm H
Weight	Approx. 100 g
Others	Raise the paper selector lever on the printer upward when scanning
	Scannable paper thickness: 0.25 mm or less

2.4.1 Scannable area

Place the image to scan in the scanning holder with the upper left corner fitted to the placement point.

Holder Type	Paper	Size (width x height)	Scannable area (width x height)
SH-101 (220 x 327 mm)	A6	105 x 148 mm	98.2 x 138 mm
	A5	148 x 210 mm	141.2 x 200 mm
	A4	210 x 297 mm	203.2 x 287 mm
	B5	182 x 257 mm	175.2 x 247 mm
	Letter	8.5 x 11 inch	208.2 x 269.4 mm
SH-102 (300 x 458 mm)	A3	297 x 420 mm	289 x 410 mm
	Ledger	11 x 17 inch	272.6 x 421.8 mm
	Legal	8.5 x 14 inch	208.2 x 332.6 mm
	B4	257 x 364 mm	250.2 x 354 mm

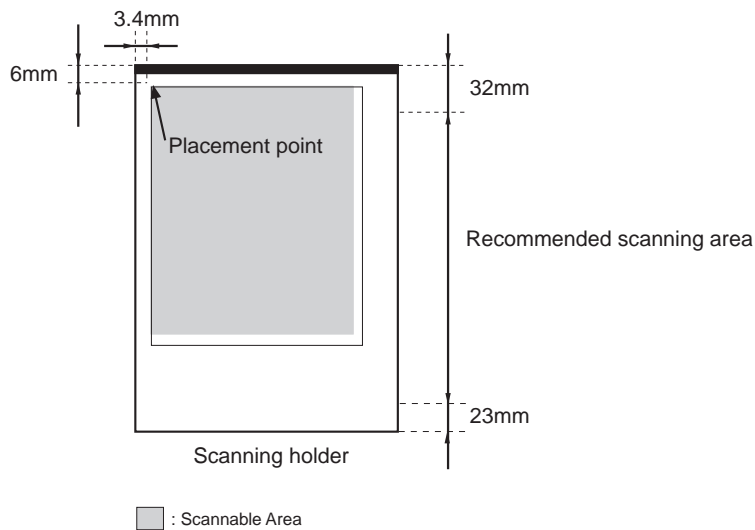

Figure 1-3 Scannable Area

2.5 Interface Specifications

2.5.1 Parallel interface

1) Interface type

IEEE 1284 compatible parallel interface

2) Data transfer

8-bit parallel interface (supports nibble/ECP modes)

3) Signal voltage levels

Input:

"Low" level: 0.0V to +0.8V

"High" level: +2.4V to +5.0V

Output:

"Low" level: 0.0V to +0.8V

"High" level: +2.4V to +5.25V

4) Input/output

Each signal pulled up with +5V

5) Interface cable

Twisted-pair double shielded cable, shorter than 2.0m

IEEE 1284 compatible required

Material: AWG No. 28 or higher (AWG: American Wire Gauge)

6) Interface connector

Printer-side Amphenol 57-40360 (or equivalent)

Cable-side Amphenol 57-30360 (or equivalent)

7) Input/output signal and pin arrangements

Refer to *Part 5: 2. CONNECTOR POSITIONS AND PIN ASSIGNMENT (Page 5-6)* for details.

2.5.2 Serial interface

1) Interface type

USB Interface (Universal Serial Bus; USB Specification Release Number 1.10)

2) Data transfer

Control transfer method

Bulk transfer method

3) Signal voltage level

Input:

Input difference sensitivity: +0.2V (Max)

Common-mode difference: +0.8V to +2.5V

Output:

Static output high: +2.8V to 3.6V

Static output low: less than +0.3V

4) Input/output

Each signal pulled up with 3.3V

5) Interface cable

Twisted-pair shielded cable

USB standard compatible required

Material AWG No.28, Data pair (AWG: American Wire Gauge)

AWG No.20 to No.28, Power distribution pair

6) Interface connector

Printer-side USB standard, Series B receptacle

Cable-side USB standard, Series B plug

7) Input/output signal and pin arrangements

Refer to *Part 5: 2. CONNECTOR POSITIONS AND PIN ASSIGNMENT (Page 5-6)* for details.

2.6 Printer Driver / Scanner Driver Types

For support of dual interfaces (USB and Centronics) and scanner, 6 drivers are prepared.

- Windows: BJ Raster driver for Windows 95 / 98*¹
 BJ Raster driver for Windows NT 4.0*¹
 BJ Raster driver for Windows 2000*¹
 Scanner driver for Windows 95 /98 NT 4.0 (Windows 2000 not supported) *¹
- Macintosh: BJ printer driver for Macintosh
 Scanner driver for Macintosh

Available combinations of interface and driver under each OS are given in the table below.

OS	For use of the printer (BJ Raster driver)		For use of the scanner (Scanner driver)	
	Parallel interface	USB interface	Parallel interface* ³	USB interface
Windows 95 / 98	○	△ * ²	○	△ * ²
Windows NT 4.0	○	×	○	×
Windows 2000	○	×	×	×
Macintosh	×	○	×	○

- : Usable.
 △ : Usable on condition.
 × : Not usable

*1: At installation of the driver, select either parallel or USB according to the cable connected.

*2: Correct operation is guaranteed only for Windows 98 pre-installed computers, though the USB interface may operate under Windows 95.

*3: The parallel interface operates in the nibble or ECP modes.

3. PRINTER PACKING

After opening the printer box, confirm that all items below are included.

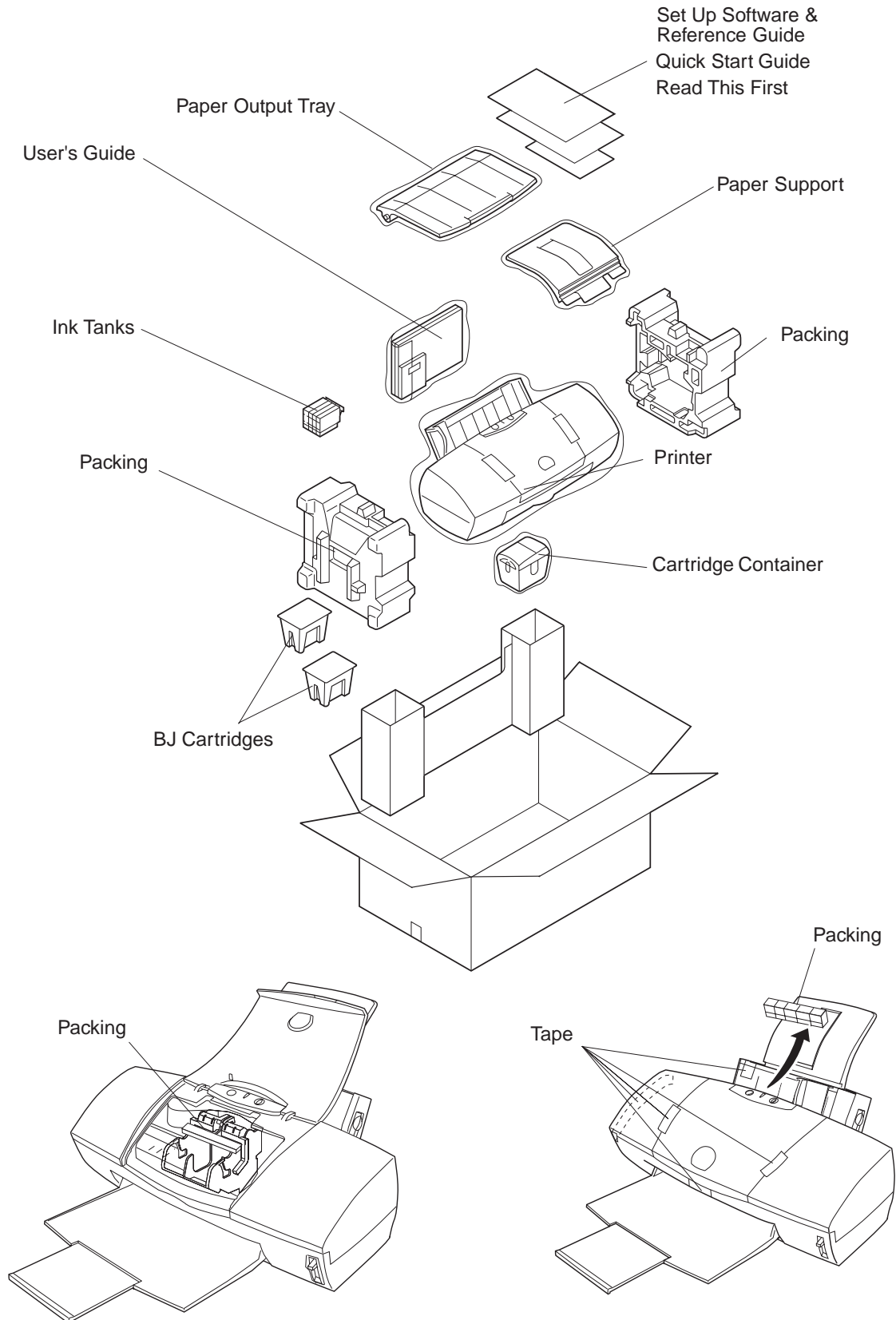

Figure 1-4 Packaging

PRODUCT SPECIFICATIONS

4. NAMES OF PARTS AND THEIR FUNCTIONS

The names of the printer parts, and their functions are as shown below.

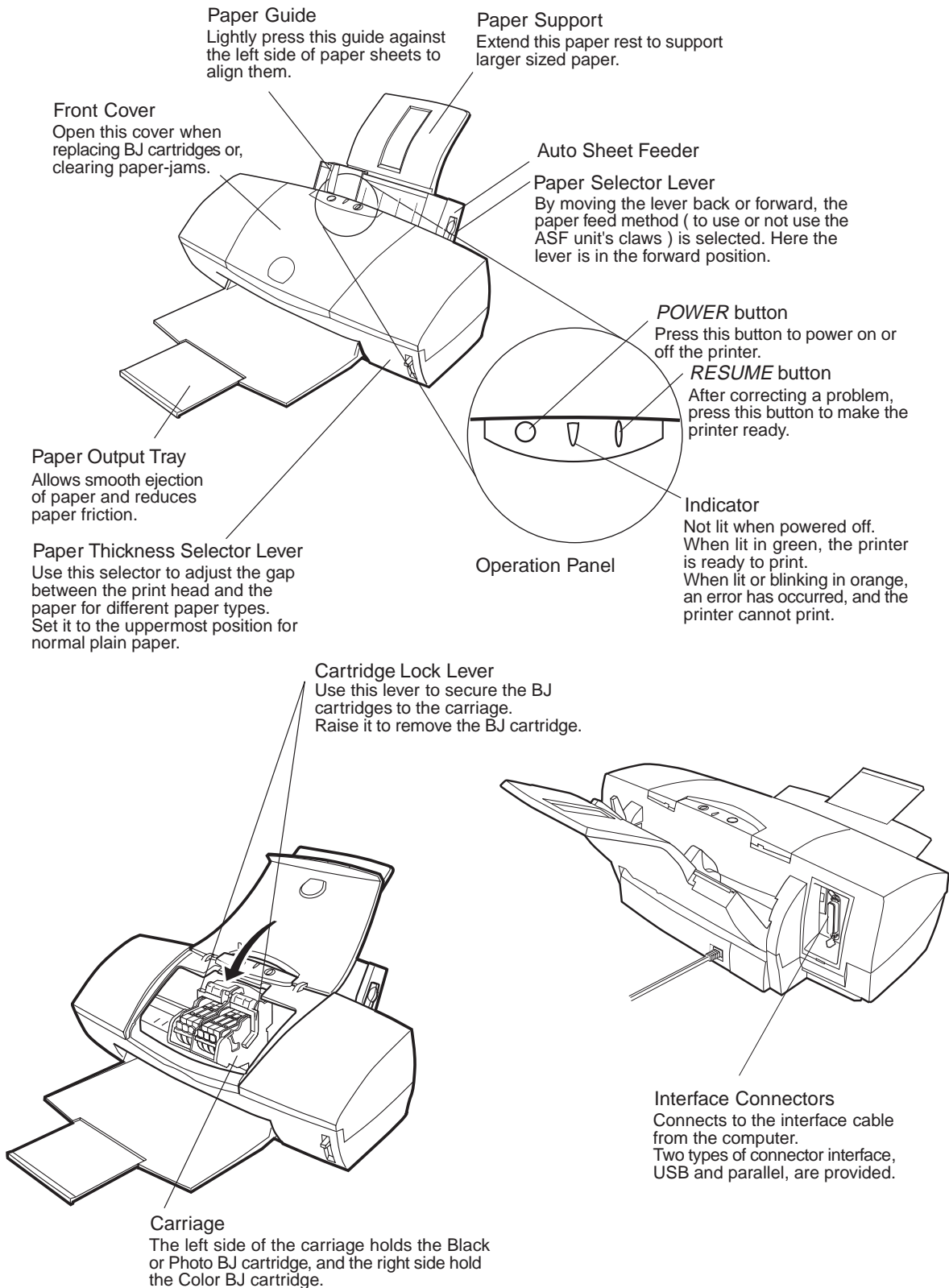

Figure 1-5 Names of Parts and Their Functions

5. PRODUCT CODE LIST

The product codes for the printer, consumables, and options are shown in *TABLE 1-1*.

Item		Name	Product code
Printer	-	BJC-6500	Q30-3300
			Q30-3182
BJ cartridge	Black	BC-30	F45-1471
	Color	BC-31	F45-1491
	Photo	BC-32 Photo	F45-1511
Ink tank	Black	BCI-3BK	F47-2171
	Cyan	BCI-3C	F47-2181
	Magenta	BCI-3M	F47-2191
	Yellow	BCI-3Y	F47-2201
	Photo Black	BCI-3PBK Photo	F47-2231
	Photo Cyan	BCI-3PC Photo	F47-2211
	Photo Magenta	BCI-3PM Photo	F47-2221
Cartridge container	-	SB-30	Q70-4040
Scanner cartridge	-	IS-32	Q70-4070
Scanning holder for A4, LTR	Scanning Holder	SH-101	Q70-3640
Scanning holder for A3, LDR	Scanning Holder	SH-102	Q70-4140

This page intentionally left blank

Part 2

MAINTENANCE

Page	
2 - 1	1. PERIODICAL REPLACEMENT/MAINTENANCE
2 - 1	1.1 Parts for Periodical Replacement
2 - 1	1.2 List of Periodical Maintenance
2 - 2	2. DISASSEMBLY AND REASSEMBLY
2 - 2	2.1 List of Tools
2 - 3	2.2 Precautions for Disassembly and Reassembly
2 - 6	2.3 Disassembling and Reassembling the Printer
2 -11	2.4 Adjustment/Setting Procedures
2 -18	3. CONFIRMATION OF OPERATION
2 -18	3.1 Confirmation Methods
2 -19	4. TRANSPORTING THE PRINTER
2 -19	4.1 Procedures for Packing the Printer for Transportation

1. PERIODICAL REPLACEMENT / MAINTENANCE

1.1 Parts for Periodical Replacement

Level	Parts for periodical replacement
User	None
Service personnel	None

Level	Consumable
User	Black BJ cartridge Color BJ cartridge Photo BJ cartridge Black ink tank for the Black BJ cartridge Cyan, magenta, and yellow ink tanks for the Color BJ cartridge Photo cyan, photo magenta, and photo black ink tanks for the Photo BJ cartridge Scanner cartridge (Optional)
Service personnel	None

1.2 List of Periodical Maintenance

Level	Location
User	None
Service personnel	None

2. DISASSEMBLY AND REASSEMBLY

2.1 List of Tools

Ordinary Tools	Note
Phillips screwdriver	For removing and replacing screws
Phillips screwdriver (about 38 mm long)	For removing and replacing screws for the control board
Blade screwdriver	For removing plastic parts
Long-nose pliers	For removing and replacing springs
Tweezers	For removing and installing flexible cables
Flat brush	For applying grease (one per grease type)
Oil applicator	For applying FLOIL 946P
Multimeter	For troubleshooting
Paperclip (diameter 1.27 mm)	Substitute for Lock Pin QY9-0053

Special Tools (part no.)	Note
1.9-mm gap gauge (QY9-0038-000)	One for head gap adjustment (see Page 2-17)
0.5-mm gap gauge (QY9-0001-000)	One for head gap adjustment (see Page 2-17)
Tension spring (QY9-0052-000)	For carriage belt tension adjustment (see Page 2-13)
Lock pin (QY9-0053-000)	For matching gear-phase of the ASF drive switching unit (see Page 2-15)
MOLYKOTE PG-641 grease (CK-0562-000)	For application to specified locations (see Page 2-10)
FLOIL 946P grease (QY9-0045-000)	For application to specified locations (see Page 2-10)

2.2 Precautions for Disassembly and Reassembly

2.2.1 Precautions for ink stains (ink paths/ink mist)

Be careful not to touch the ink paths. Ink on hands could stain the printer, work table, or clothes. The ink paths include the BJ cartridge ink tank outlet, the BJ cartridge ink filters and nozzles, the maintenance jet receiving section, the head caps, the wipers, and the waste ink absorber.



The ink is not harmful to the human body, but contains some organic solvents:

The black ink contains glycerin 56-81-5 and diethylene glycol 111-46-6. The yellow ink contains glycerin 56-81-5 and isopropyl alcohol 67-63-0. The cyan, magenta, photo-cyan, photo-magenta and photo-black ink contain glycerin 56-81-5, isopropyl alcohol 67-63-0, ethylene glycol 107-21-1, and diethylene glycol 111-46-6.

Be careful not to get the ink into your mouth or eyes. If the ink gets into your eyes, wash with plenty of water and consult a doctor. In case you have swallowed a large amount of ink, consult a doctor immediately. The ink contains dyes. If clothing is stained with the ink, the ink may not be removed completely.

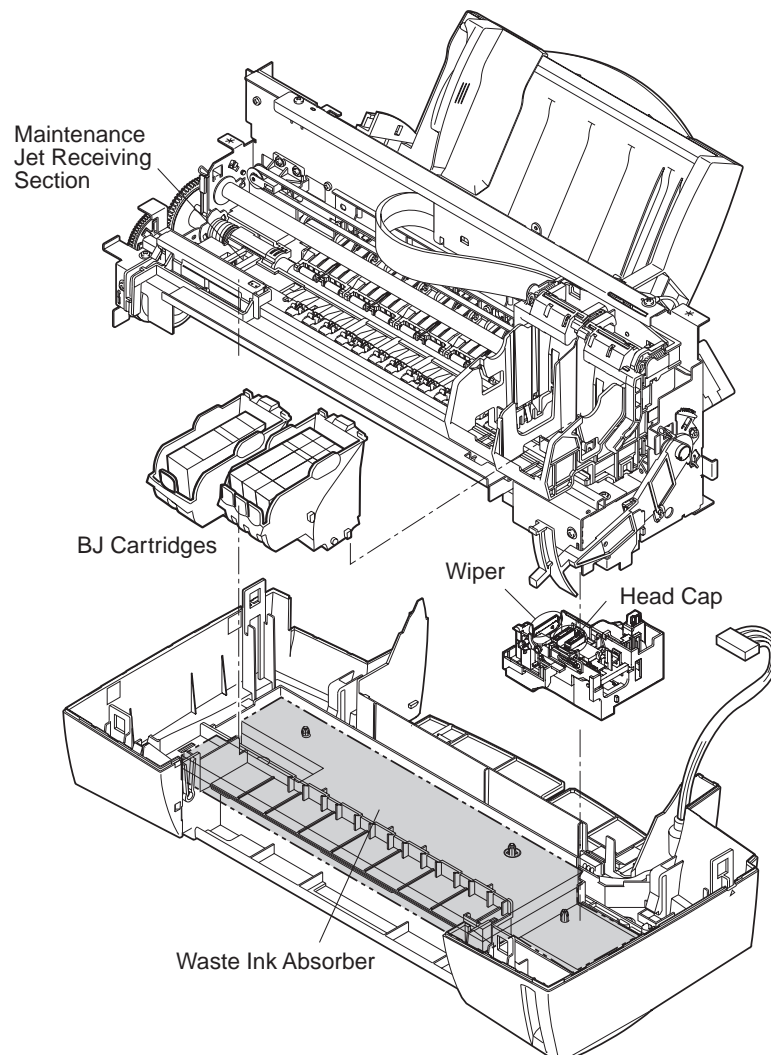

Figure 2-1 Ink Paths

The BJ cartridge ejects ink onto the paper during printing. After the printer is used for a long period or used heavily, ink mist bouncing back from the paper could accumulate and contaminate the platen (including the left and right paper guide plates), front cover, as well as the periphery of the purge unit. Carefully wipe off the ink mist with a dampened soft cloth so that hands or clothing will not be stained by contaminated parts during servicing.

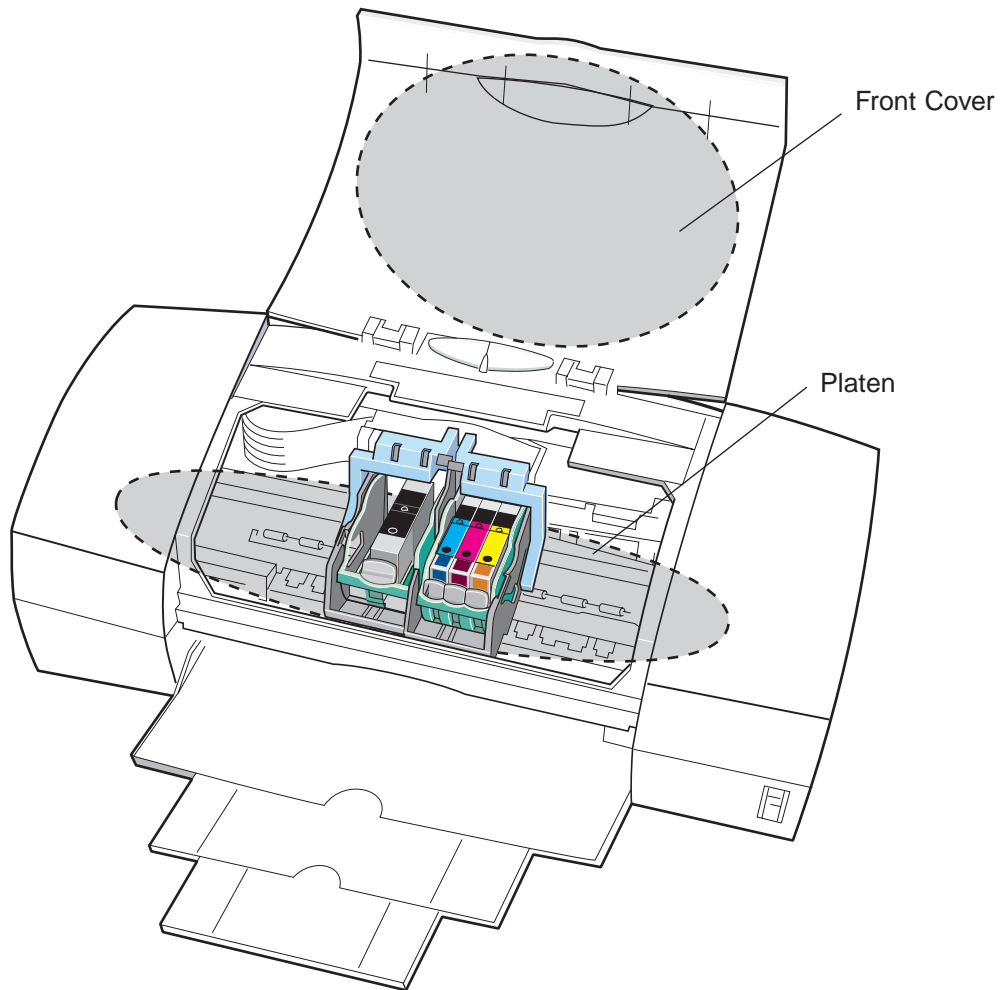

Figure 2-2 Ink Mist

2.2.2 Precautions for damage due to static electricity

Static electricity may be generated by your clothes rubbing against each other and may accumulate in your body. If you touch electrical elements, the discharge of static electricity could damage them or change their electrical characteristics. For this reason, avoid touching the ink sensor contacts or the printer's BJ cartridge contacts.

2.2.3 Precautions for transporting the printer

When turned off by the POWER button, the BJ cartridges are capped and the carriage is locked in place at the capping position by the lock arm. When the printer cannot be powered off by the POWER button for transportation, etc., move the carriage to the capping position by hand and secure it with tape before transporting the printer.

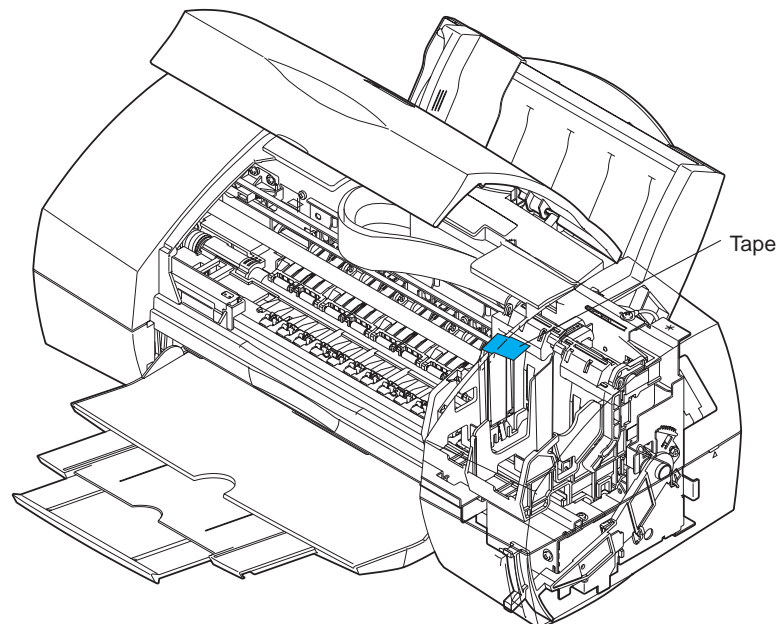

Figure 2-3 Capping Position

2.2.4 Precautions on spur tip deformation

Take care not to bend the tips of the spurs. The tips of the spurs make contact with printed paper and are contaminated with ink, but due to their small surface contact area, the tips, cleaned by the spur cleaners, will not stain the printed paper. However, if the tips are bent and their contact surface area increases, they collect more ink and are not easily cleaned by the spur cleaners, and thereby stain the printed paper by making dotted lines on it.

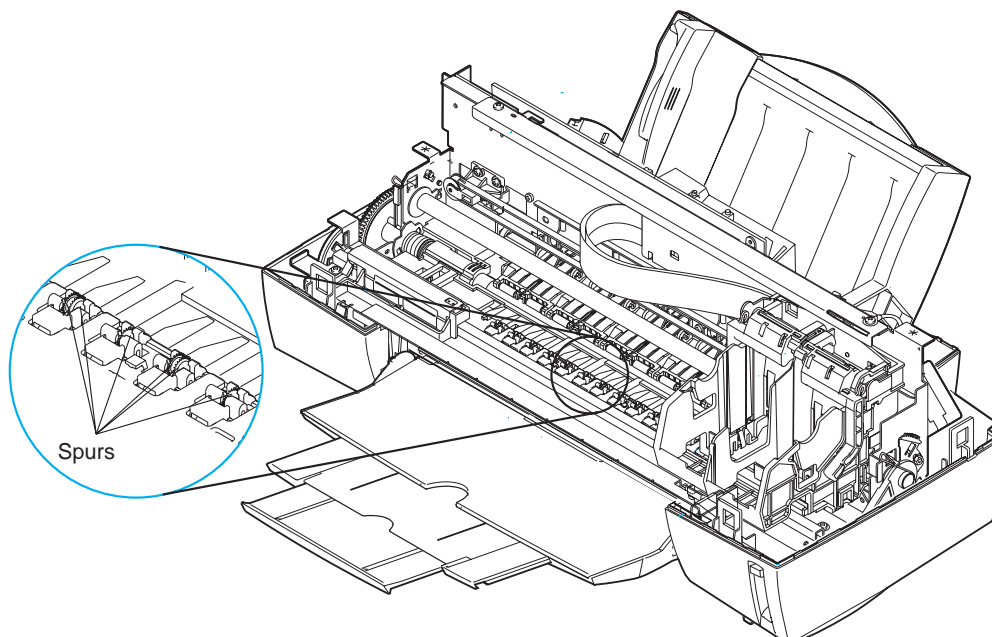

Figure 2-4 Spur Unit

2.3 Disassembling and Reassembling the Printer

Note the following when disassembling or reassembling the printer. When disassembling or reassembling the printer, refer to the parts catalog. The numbers in the parts catalog illustrations indicate the disassembly sequence.

2.3.1 Unlocking the carriage

When the printer is shipped from the factory (or when the cartridges are installed and the power has been turned off normally), the carriage is locked in the capping position to secure the cartridges during transportation. When the printer is powered on properly, the carriage locking is disabled automatically. If the printer cannot be powered on normally, it will be necessary to manually unlock the carriage. This can be done by turning the paper eject roller gear half a turn (5 indented notches) in the direction of arrow 2 with a flat-blade screwdriver while gently pressing the carriage in the direction of arrow 1. You can also use the carriage key to turn the paper eject roller gear.

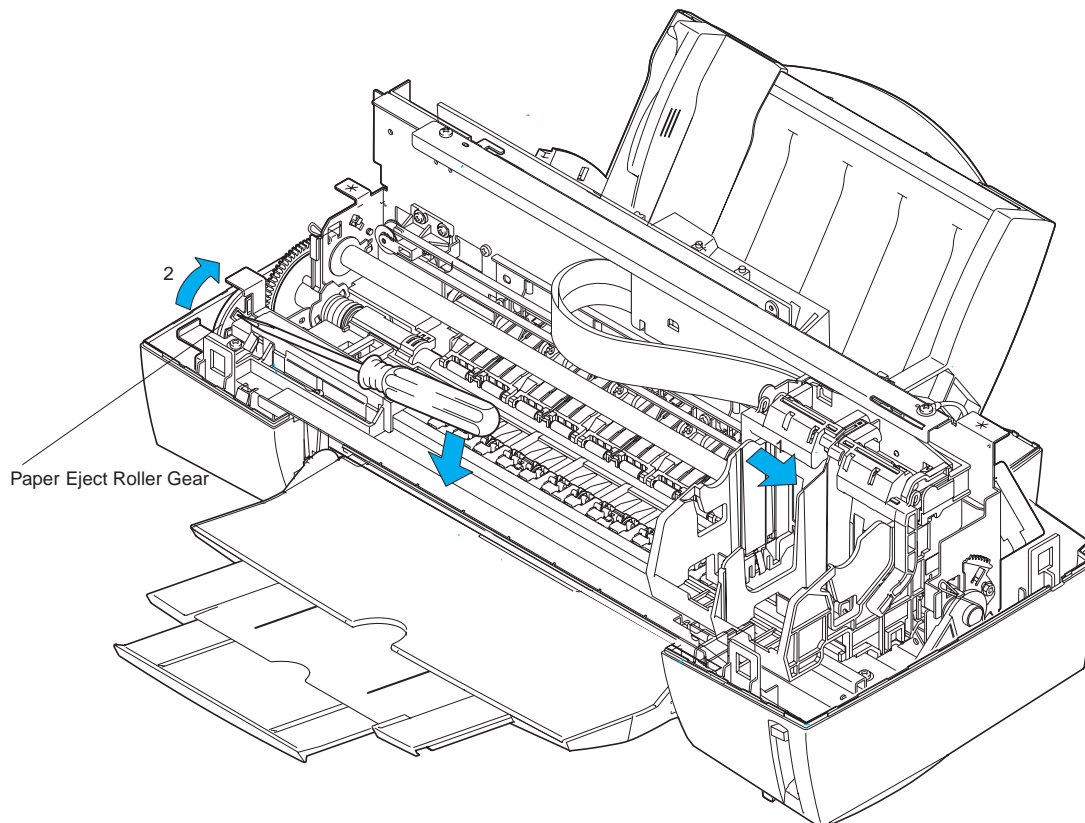

Figure 2-5 Unlocking the Carriage

2.3.2 Reinstalling tap screws

The printer unit is secured to the base with tap screws. Once tap screws have been removed, pieces of the molding remain attached to the screw threads. Reinstalling the tap screws in this condition can damage the screw threads. To prevent this, when reinstalling screws, where possible, new screws should be used.

2.3.3 Removing the printer unit

Refer to Figure 5 (page B-9) of the Parts Catalog.

- 1) As shown in 3), to easily release the tab by the carriage motor, pull the cable upwards.
- 2) Set the paper thickness lever to its lowest position (envelope position).
- 3) Press the locking tab on the right side of the printer in the direction of arrow 1 and slide the printer unit in the direction of arrow 2, resting it on the boss.
- 4) Likewise, release the locking tab on the left side of the printer and rest the left side of the printer unit on its' boss.
- 5) To avoid catching the paper thickness selector lever on the base unit, hold the printer unit by the handles on the left and right, tilt the printer unit in the direction of arrow 3, and lift upwards to remove the unit.

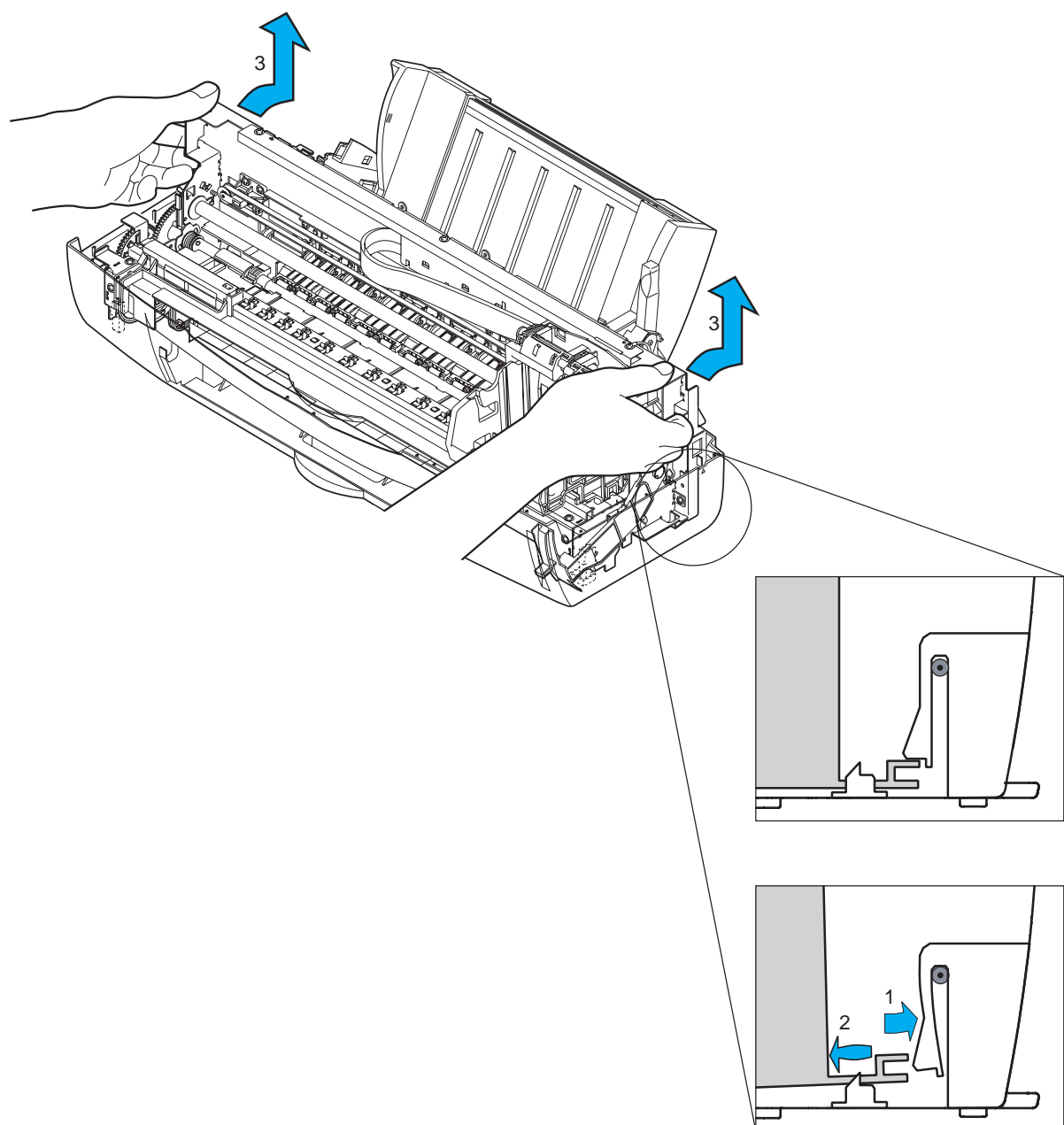

Figure 2-6 Removing the Printer Unit

2.3.4 Removing the ASF unit

The ASF unit is attached to the printer unit such that the ASF driving gear and the pick-up roller are matched in phase. Once you have removed the assembly screws, painted red to protect against careless removal, which fasten the ASF unit to the printer frame, you must readjust the position of the ASF gear with respect to that of the pick-up roller. For details, refer to *2.4.5 How to adjust the ASF gear position* (Page 2-14).

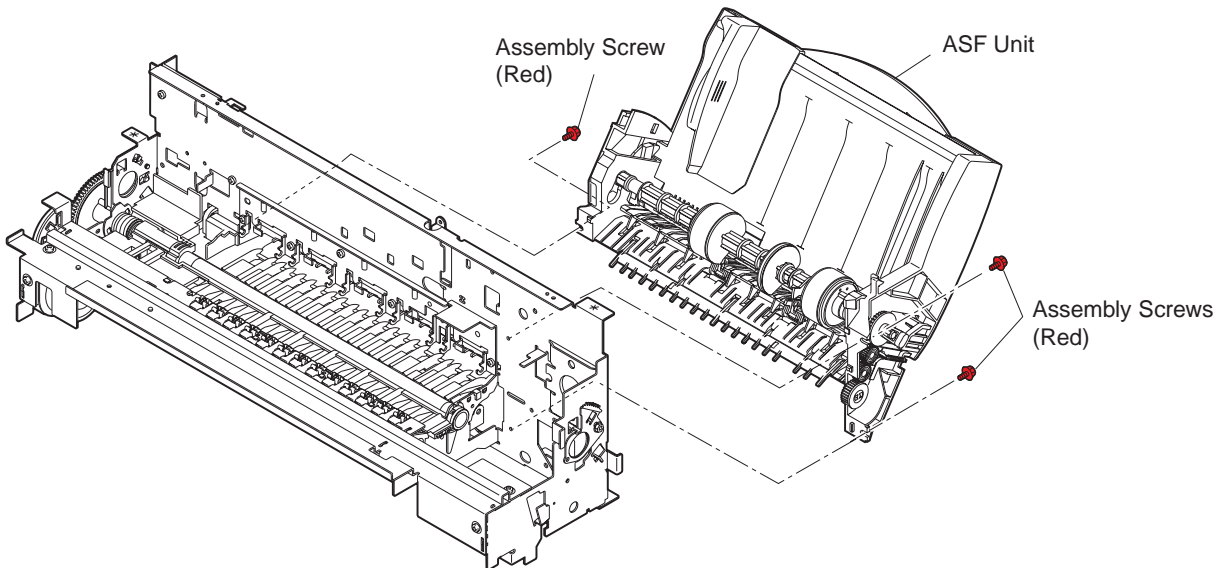

Figure 2-7 Removing the ASF Unit

2.3.5 Removing the adjustable bushings supporting the carriage shaft

The adjustable bushings supporting the carriage shaft are adjusted and secured to the printer frame so that the ideal head-to-paper gap is maintained for best print quality. Once you have loosened the screws, painted red to protect against careless removal, which fasten the adjustable bushings to the printer frame, you must readjust the position of the bushings for head gap adjustment. For details, refer to *2.4.6 How to adjust the head gap* (Page 2-16).

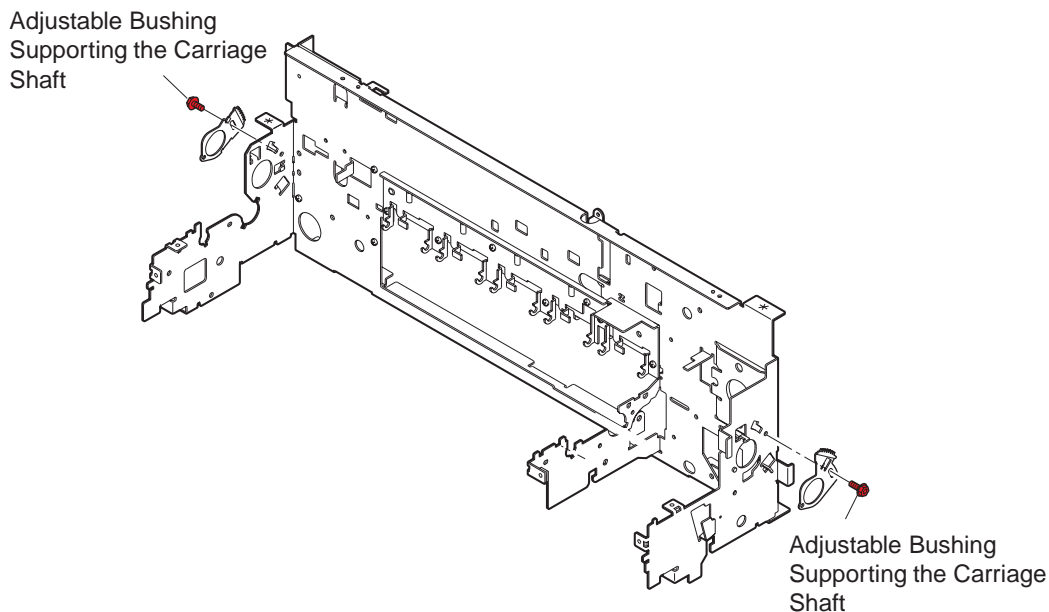

Figure 2-8 Adjustable Bushings Supporting the Carriage Shaft

2.3.6 Paper feed gear handling

Be careful not to touch the gears (eject roller's, feed roller's) in the paper feed unit, especially the paper feed gear, during disassembly or reassembly, because even slight damage to it could affect paper feeding when printing at high resolution.

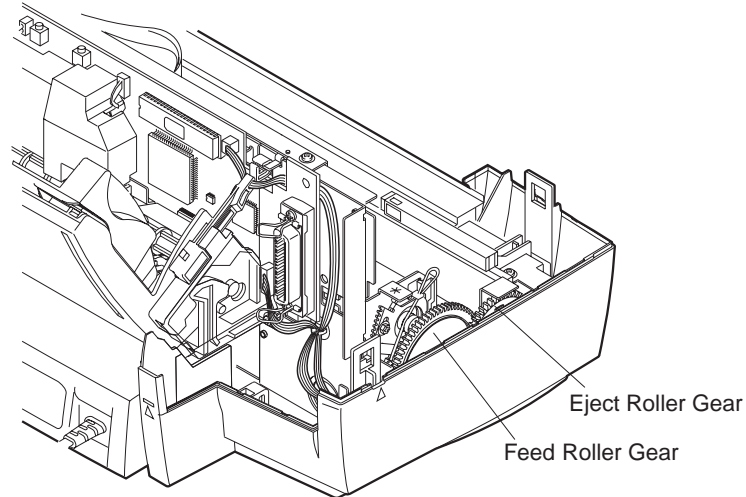

Figure 2-9 Paper Feed Gears

2.3.7 Spur holder assembly installation

Because removing and installing the spur holder ass'y affects the head gap, be sure to perform the following procedures when installing the spur holder ass'y.

- (1) By hand, pinch the spur holder ass'y and chassis together, and tighten the center screw (1).
- (2) Similarly, tighten the left and right screws (2, 3).
- (3) Then tighten the remaining 2 screws in the upper unit.

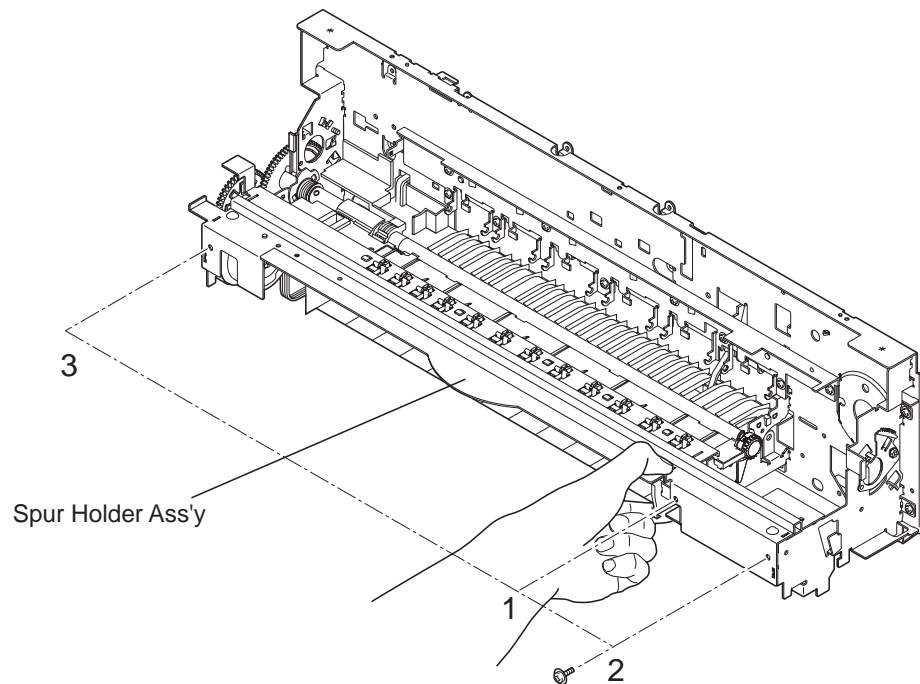

Figure 2-10 Spur Holder Ass'y Installation

2.3.8 Grease application points

Apply greases at the points shown below.

Apply a thin film of grease using the flat brush. For the Carriage Oil Pad, do not use a brush but apply directly.

For disassembly and reassembly procedures, refer to the parts catalog.



Do not apply more than the specified amount of grease, especially to the grease pad.

If grease gets on the wipers or caps, damage is likely to occur.

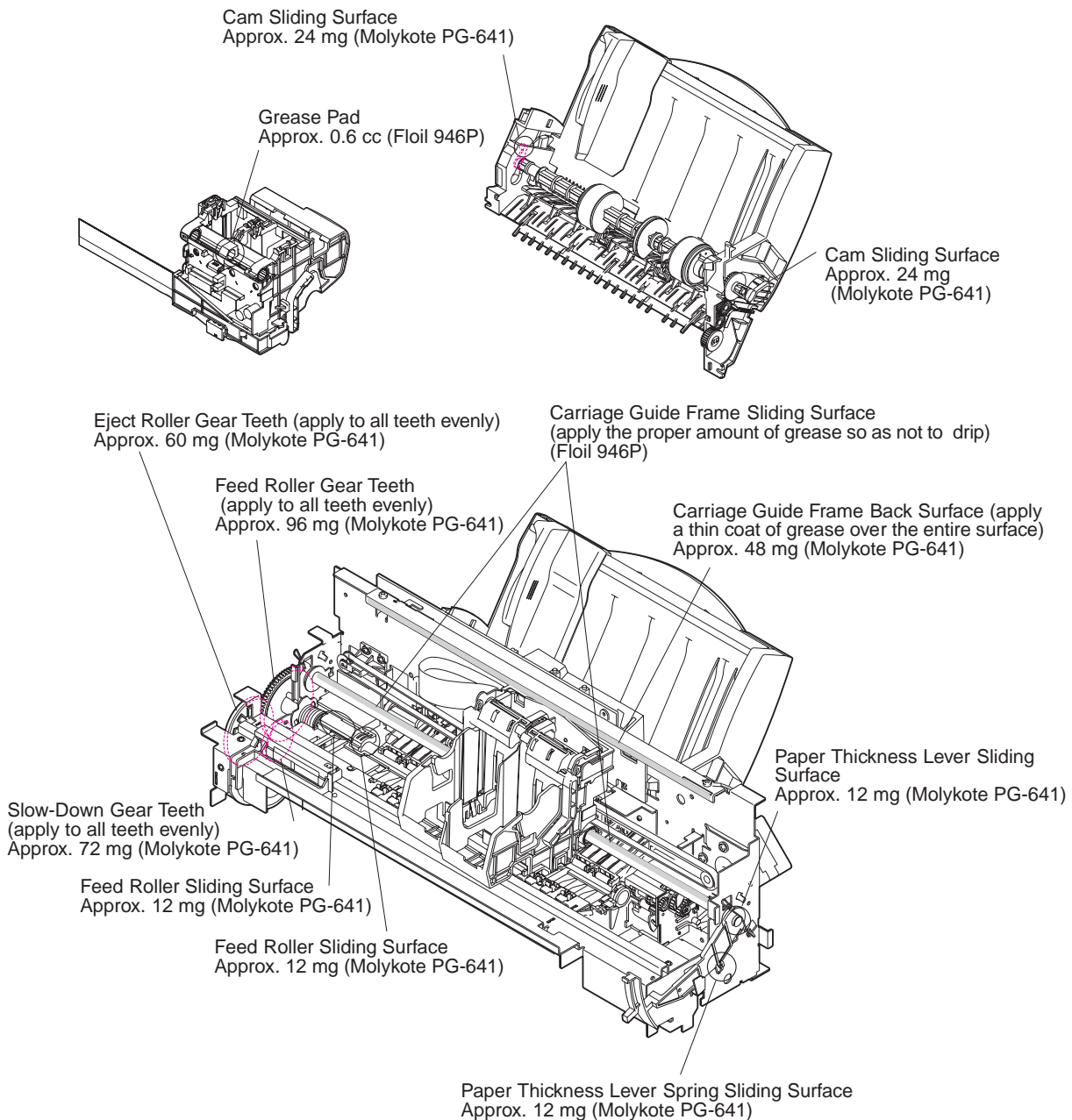

Figure 2-11 Grease Points

2.4 Adjustment/Setting Procedures

2.4.1 Adjustments (item, adjustment points, tools)

(1) User Level

Item	Adjustment point	Time	Tools
BJ Cartridge	Print head position adjustment (Page 2-12)	2 min.	1 sheet of B5-sized or larger paper.

(2) Service personnel level

Item	Adjustment point	Time	Tools (Page 2-2)
Reinstalling the ASF	ASF gear position adjustment (Page 2-14)	2 min.	Lock pin or paperclip
Reinstalling the Idler Pulley	Carriage belt tension (Page 2-13)	1 min.	Tension spring
Control Board replacement Waste Ink Absorber replacement	Resetting the EEPROM (Page 2-13)	1 min.	None
Carriage unit related parts replacement or disassembly	Print head position adjustment (Page 2-12)	2 min.	1 sheet of B5-sized or larger paper
Loosening of head-paper screw	Head gap (Page 2-16)	5 min.	Gap gauge

2.4.2 When to perform print head position adjustment

As there are two BJ cartridges installed in this printer, even a slight difference in size or seating position between them may result in inaccurate dot placement, and thereby poor printing. To correct this, after installing the BJ cartridges, perform the automatic print head position adjustment, one of the utilities the printer driver package provides. If a computer is not available, you can still perform the print head position adjustment in service mode. For the procedures, refer to *Part 3: 2.1 Service Mode Operations* (Page 3-8). Set at least one sheet of B5 (or larger) plain paper in the ASF, and select the print head position alignment pattern in the test print area of the printer driver's Utility sheet.

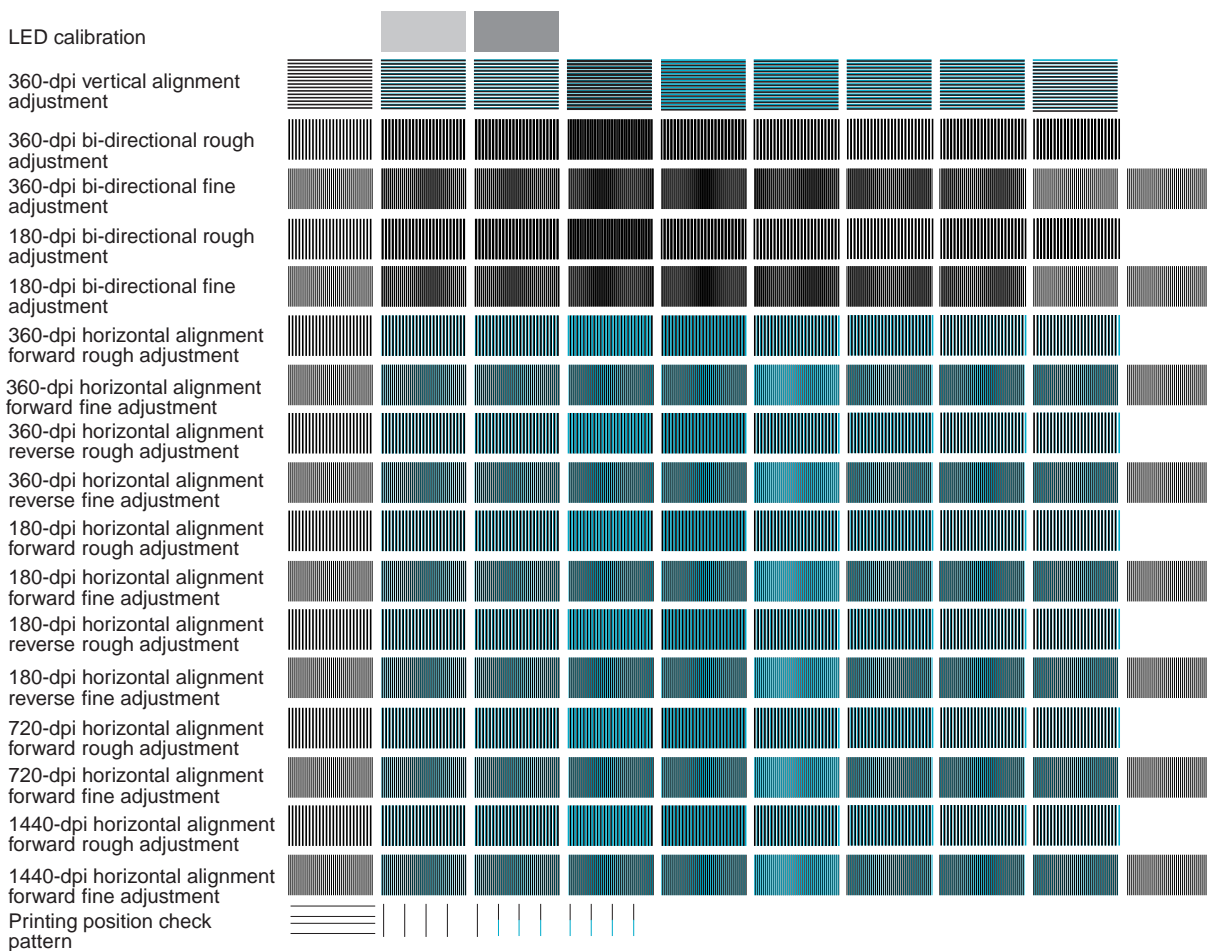

Figure 2-12 Print Position Adjustment Pattern



When printing the print head position adjustment pattern, do not use paper smaller than B5-sized paper. Use paper of B5 size or larger for the nozzle check pattern printing. If you use smaller paper, the platen may be smeared with ink.

2.4.3 When to reset the EEPROM

The EEPROM (IC11) on the control board stores total amount of waste ink absorbed, function settings, and other information specific to the printer. Due to this, in the following situations, it will be necessary set the model or reset the EEPROM. For details, refer to *Part 3: 2.1 Service Mode Operations* (Page 3-8).

1) On replacement of the control board.

Upon replacement of the control board, visually check the waste ink absorber's ink level and replace if it is more than 7% filled, and reset the EEPROM. If the EEPROM is not reset, waste ink could leak before the printer issues the waste ink full warning. Since the EEPROM data of a replacement control board is not defined, you must always set the model.

2) On replacement of the waste ink absorbers.

The EEPROM's waste ink counter should be cleared, or the EEPROM reset.



Previous EEPROM data cannot be confirmed with the test printing once the EEPROM has been reset. Always perform a test print before resetting the EEPROM, as all information such as function status, number of sheets passed, waste ink amount, etc., except for the model setting, will be lost when the EEPROM is reset.

It is not possible to write data (such as waste ink amount, model, etc.) of the old EEPROM to the EEPROM of a replacement control board



The waste ink full error should not occur before the life of the printer has been reached. However, frequently powering on/off, replacing the BJ cartridge, opening the front cover (automatic cleaning), or usage conditions may cause this error to occur earlier.

2.4.4 How and when to adjust the carriage belt tension

When the carriage belt tension has been loosened to replace the carriage, or for other reasons, insert the tension spring (QY9-0052-000) in the correct position to adjust the belt tension, and fix the idler pulley assembly by tightening the fixing screws, and remove the tension spring.

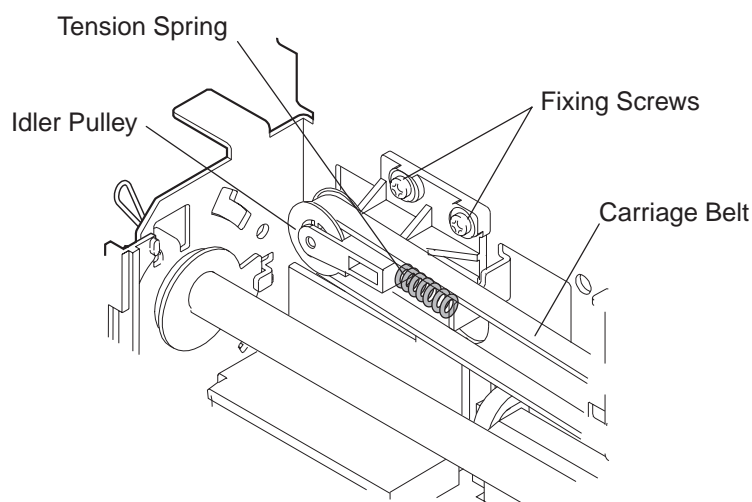

Figure 2-13 Carriage Belt Tension Adjustment

2.4.5 How to adjust the ASF gear position

The ASF gear position adjustment matches the phasing of the ASF pick-up roller and ASF drive switching gear. For this reason, the initial positions of the ASF gear and the ASF drive gear must be aligned.

Preparation:

- 1) Reassemble the ASF unit components to the level as when the ASF unit was detached.

Adjustment procedure:

- 1) Slowly turn the ASF drive gear by finger in the direction of the arrow.
- 2) Stop turning when the gear "clicks" (becomes easy to turn). (To confirm the position, gently move the ASF drive gear up and down).
- 3) If the gear has passed the initial position, continue turning the gear in the same direction to return to the correct position.
- 4) Turn the pick-up roller so that the ASF cam is positioned as shown in the diagram.
- 5) Align the ASF gear 1 and the ASF unit's protruding mark as shown in the diagram.

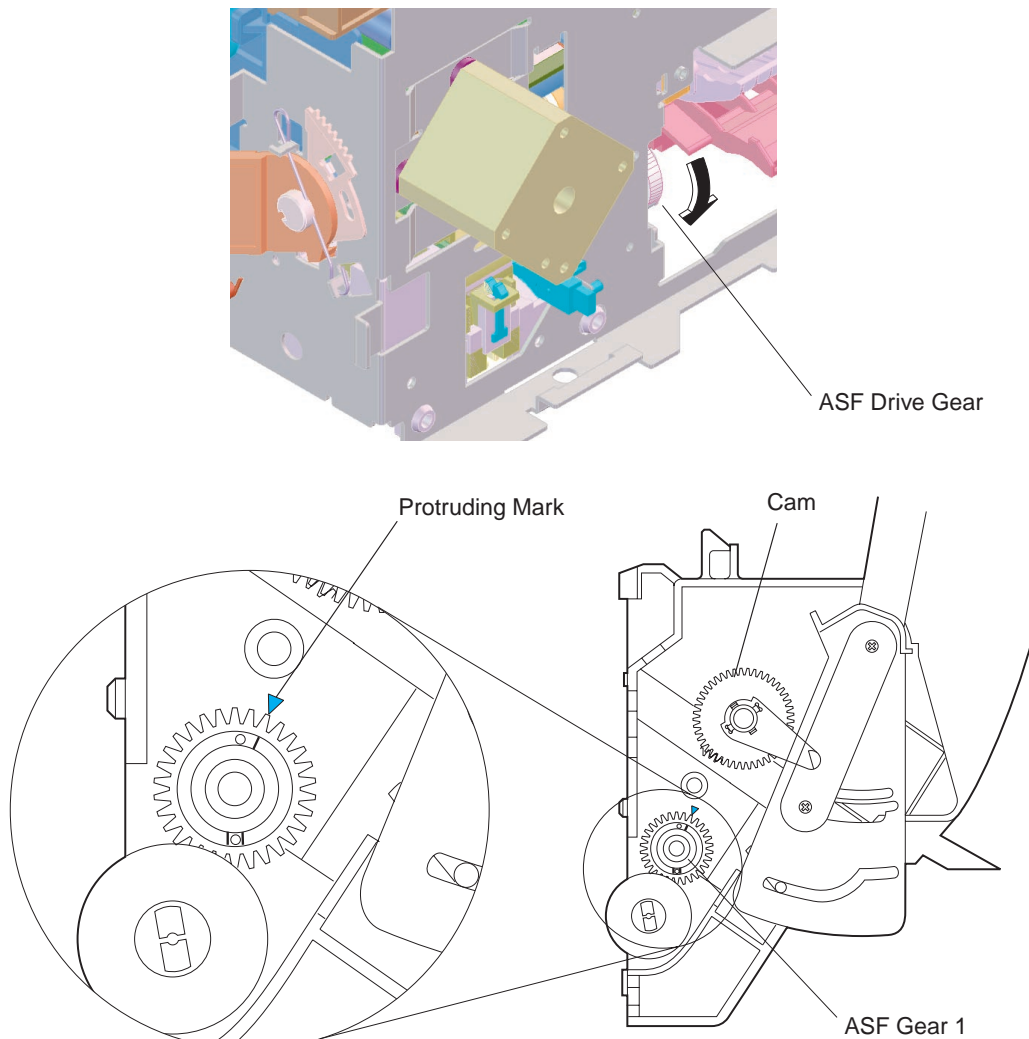
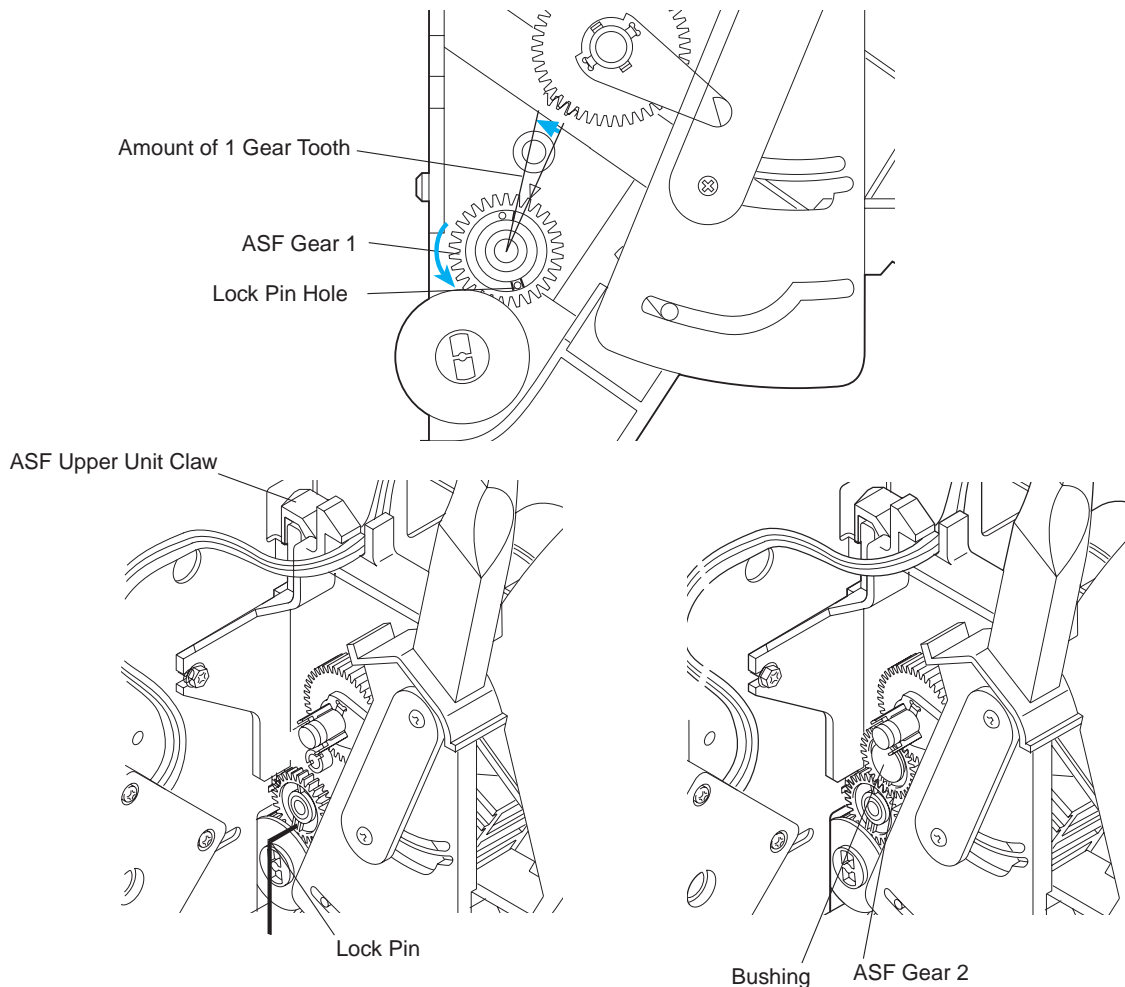

Figure 2-14 ASF Gear Position Adjustment 1

Adjustment procedure:

- 1) To prevent the gear position from changing, press a finger against the gear and fix the ASF unit to the chassis, by tightening the screws.
By hooking the claw of the upper ASF to the chassis, smoothly lower the ASF to install it.
- 2) Turn ASF gear 1 in the direction of the arrow in the amount of 1 gear tooth.
- 3) To hold ASF gear 1 in place, insert the lock pin (QY9-0053) into the lock pin hole.
Be sure to pass the pin through ASF gear 1 and into the hole in the ASF base.
- 4) Attach ASF gear 2.
- 5) Secure ASF gear 2 to the ASF unit with the Bushing (QB-4150-000).
- 6) Remove the lock pin from the ASF unit.

**Figure 2-15 ASF Gear Position Adjustment 2**

Do not insert the lock pin into the lock pin hole before the ASF unit is secured to the chassis. By doing so, the gears cannot be matched in phase.

2.4.6 How to adjust the head gap

Preparation:

- 1) Reassemble to the level the top cover is to be put on next.
- 2) Raise both the right and left adjustable bushings supporting the carriage shaft as shown by arrow 1, and temporarily fix the bushings in that position using the fixing screws.
- 3) Remove the right and left shaft clips from the carriage shaft.
- 4) Set the paper thickness selector to the lowest position (thick paper position)



Ensure that the gap gauges are clean and not deformed. Also ensure that the platen is clean.

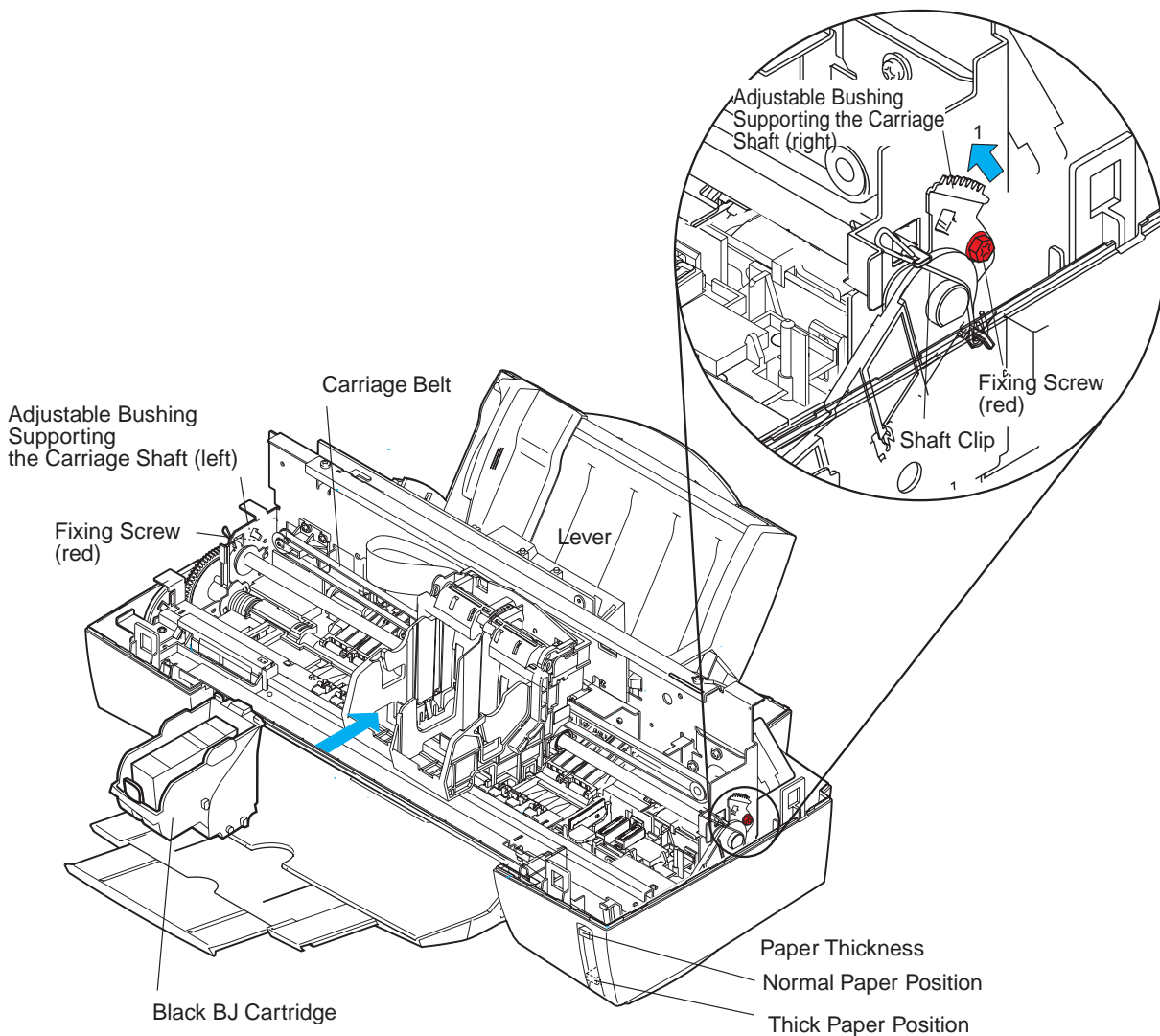
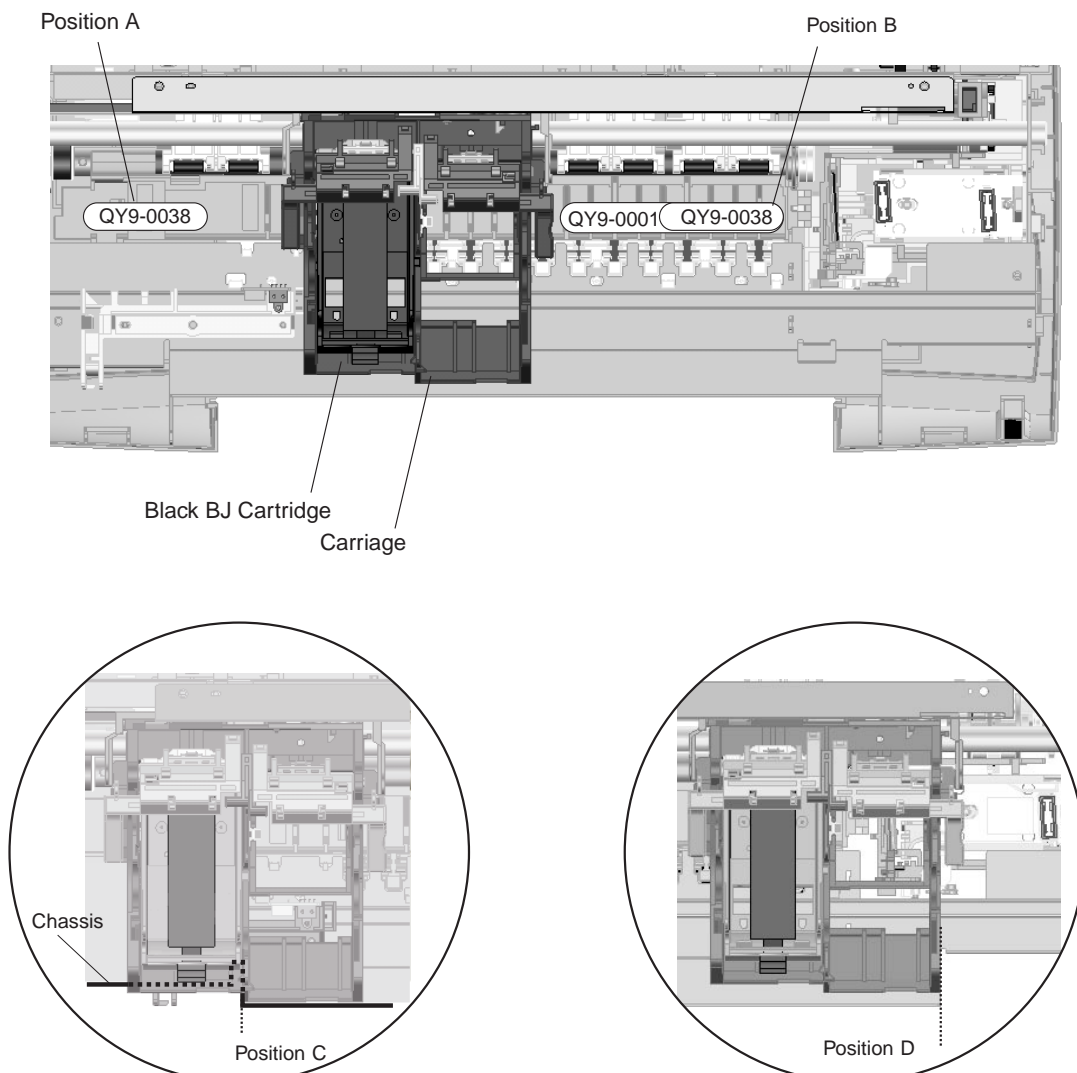

Figure 2-16 Head Gap Adjustment 1

Adjustment procedure:

- 1) Set the 1.9-mm gap gauge (QY9-0038) in position A.
- 2) Move the carriage into position C by moving the carriage belt by hand.
- 3) Install the Black BJ cartridge on the left side of the carriage.
- 4) Loosen, by half a turn, the fixing screw locking the carriage shaft's left adjustable bushing, move the paper thickness lever up/down 2 or 3 times, and tighten the fixing screw.
- 5) Remove the Black BJ cartridge.
- 6) Stack the 0.5mm gap gauge (QY9-0001) and the 1.9mm gap gauge (QY9-0038) together in position B.
- 7) Set the paper thickness lever to the lowest position (thick paper position).
- 8) Move the carriage into position D by moving the carriage belt by hand.
- 9) Install the Black BJ cartridge on the left side of the carriage.
- 10) Loosen, by half a turn, the fixing screw locking the carriage shaft's right adjustable bushing, move the paper thickness lever up/down 2 or 3 times, and tighten the fixing screw.
- 11) Remove the Black BJ cartridge.
- 12) Repeat steps 1) to 11) again before continuing to 13).
- 13) Firmly tighten the right and left fixing screws.
- 14) Reinstall the right and left shaft clips in place.

**Figure 2-17 Head Gap Adjustment 2**

3. CONFIRMATION OF OPERATION

3.1 Confirmation Methods

Confirming the operation of the printer after reassembly is possible by conducting the following procedures:

1) Offline, perform the print head position adjustment.

Confirm that the print head position adjustment can be performed. For procedures, refer to *Part 3: 2.1 Service Mode Operations* (Page 3-8).

2) Offline, perform the service/factory test print.

Confirm that the printing is correctly performed and that after 1) that misalignment does not appear. For procedures, refer to *Part 3: 2.1 Service Mode Operations* (Page 3-8).

After replacing either the control board or the waste ink absorber, in addition to 1) and 2), it is necessary to confirm the following:

On replacement of the:	Confirm that:
Control board	On the service/factory test print, that the ROM version and model name are correct, and that the number of sheets passed and the total waste ink amount have been cleared.
Waste ink absorber	On the service/factory test print, that the total waste ink amount has been cleared.

4. TRANSPORTING THE PRINTER

To prevent the ink from leaking or drying out in the nozzles during transportation, keep BJ cartridges installed in the printer, capped, or stored in the cartridge container. Refer to *Part 2: 2.2.3 Precautions for transporting the printer* (Page 2-5).

To prevent ink leakage, transport the printer with the ink tanks installed in the BJ cartridge.

Transport the printer (for service or return) with the carriage locked in place.

4.1 Procedures for Packing the Printer for Transportation

When transporting the printer, follow the procedures below:

- 1) Press the *POWER* button to turn off the printer. After the printer moves the carriage to the home position and locks the carriage in place, the indicator will go out. Or, by entering the Service Mode and pressing the *RESUME* button, the printer will power off after locking the carriage. For details, refer to (*Part 3: 2.8 Powering Off and Locking the Carriage* Page 3-11).
- 2) Disconnect the interface cable.
- 3) Unplug the power cord from the wall outlet.
- 4) Open the front cover and visually confirm that the carriage is locked in the capping position (on the right side of printer). If the carriage is not in the capping position, move it manually to the capping position by using the carriage belt, and secure it there with tape.
- 5) Secure the cartridge lock lever in place with tape.
- 6) Close the cover.
- 7) Pack the printer in its' original packing in its' original carton. If the original packing materials are not available, wrap the printer with sufficient shock absorbing material.



Do not unplug the printer before switching off the printer with the *POWER* button, otherwise, the BJ cartridges' nozzles will not be capped, which may result in ink leaking or drying-out. Do not carry a BJ cartridge and its ink tanks separately.

This page intentionally left blank

Part 3

OPERATION

Page	
3 - 1	1. FUNCTIONS RELATED TO PRINTER OPERATION
3 - 1	1.1 Status Display
3 - 5	1.2 Operations from the Computer
3 - 6	1.3 Operations from the Printer
3 - 8	2. SERVICE FUNCTIONS
3 - 8	2.1 Service Mode Operations
3 - 9	2.2 Printing the Service/Factory Test Print
3 -10	2.3 Printing the EEPROM Information
3 -11	2.4 Resetting the EEPROM
3 -11	2.5 Setting the Model
3 -11	2.6 Checking the Presence of Ink
3 -11	2.7 Conducting the Print Head Position Adjustment
3 -11	2.8 Powering Off and Locking the Carriage

1. FUNCTIONS RELATED TO PRINTER OPERATION

For the BJC-6500, functions for printer operation such as display of the status, operation from the computer, and operation from the printer itself, are built-in.

1.1 Status Display

The printer displays the status via the indicator lamp and the beeper. The number of times the indicator flashes and the beeper beeps are used to determine the error status.

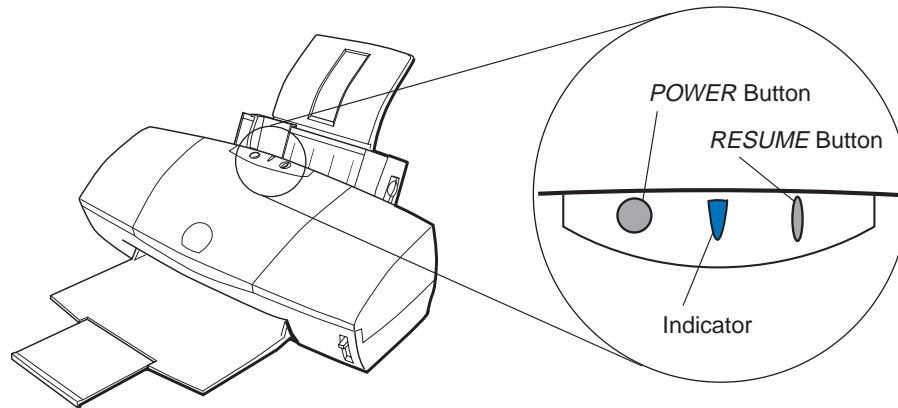

Figure 3-1 Operation Panel

1.1.1 Status display via the indicator

Display of the status via the indicator is as shown in Table 3-1 below.

TABLE 3-1 STATUS DISPLAY VIA THE INDICATOR

Normal operation				
Status	Indicator	Beeps	Error code	Reference page
When powered-on	Lights in Green
During power-on	Blinks in Green
During power-off	Blinks in Green
While resetting	Blinks in Green
During cleaning	Blinks in Green
Service/Factory test printing	Blinks in Green
Front cover open	Blinks in Green
During printing	Blinks in Green
When in error				
Error	Indicator	Beeps	Error code	Reference page
[Recoverable by user]				
Paper feed error	Lights in Orange	2 times		Page 4-13
Paper jam error	Lights in Orange	3 times		Page 4-13
Ink out error	Lights in Orange	4 times		Page 4-15
BJ Cartridge mis-installed error	Lights in Orange	5 times		Page 4-16
No BJ cartridge error	Lights in Orange	6 times		Page 4-16
BJ Cartridge error	Lights in Orange	7 times		Page 4-16
Waste ink warning error	Lights in Orange	8 times		Page 4-6
Head position adjustment error	Lights in Orange	9 times		Page 4-17
[Unrecoverable by user]				
ROM error	Blinks in Orange 1 time	10 times		Page 4-6
RAM error	Blinks in Orange 2 times	10 times		Page 4-6
EEPROM error	Blinks in Orange 3 times	10 times	6800	Page 4-6
Home position error	Blinks in Orange 4 times	10 times	5100	Page 4-7
Printer temperature sensor error	Blinks in Orange 5 times	10 times	5400	Page 4-6
Waste ink full error	Blinks in Orange 6 times	10 times	5B00	Page 4-6
Head temperature error	Blinks in Orange 7 times	10 times	5200	Page 4-10
Head temperature sensor error	Blinks in Orange 8 times	10 times	5200	Page 4-10
Cartridge displaced error	Blinks in Orange 9 times	10 times	5600	Page 4-11
ASF sensor error	Blinks in Orange 10 times	10 times	5700	Page 4-12
[Internal errors]				
Ink sensor error	No indication	None	5910	Page 4-18

Note: Internal errors are not displayed, but can be checked by printing the EEPROM information. See (Page 3-10)

Description of Error Indications**Errors recoverable by users:****1) Paper feed error**

Paper feed operation fails to feed paper.

2) Paper jam error

Paper eject operation of 23 inches fails to eject the paper.

3) Ink out error

The indicated ink tank is out of ink (ink chamber and sponge).

4) BJ Cartridge mis-installed error

The BJ cartridges are not installed in their correct positions.

5) No BJ cartridge error

One or both of the BJ cartridges are not installed.

The scanner cartridge is installed in the color (right) cartridge side.

6) BJ Cartridge error

One or both of the BJ cartridges are defective (unreadable ID, or out-of-range rank).

7) Waste ink warning

The amount (stored in EEPROM) of waste ink absorbed is at 95% of the defined capacity.

8) Head position adjustment error

The automatic head position adjustment has failed.

Errors unrecoverable by users:**9) ROM error**

ROM checking during initialization is NG.

10) RAM error

RAM checking during initialization is NG.

11) EEPROM error

Writing to EEPROM has failed.

12) Home position error

The home position sensor is defective (broken circuit) or fails to detect home position.

13) Temperature sensor error

The thermal sensor (TH1) on the logic board is defective (broken circuit).

14) Waste ink full error

The amount (stored in EEPROM) of waste ink absorbed is at 100% of the defined capacity.

15) Head temperature error

The inside temperature of the BJ cartridge is too high. This error should occur earlier than the head temperature sensor error.

16) Head temperature sensor error

The thermal sensor in the BJ cartridge is defective.

17) Cartridge displaced error

The printer cannot detect the BJ cartridge when the carriage is out of the cartridge replacement position.

18) ASF sensor error

The pick-up roller doesn't turn during paper feeding, or the pick-up roller doesn't detect the pick-up roller's flag.

19) Ink sensor error

During the ink sensor check at initialization, it will be reported that there is ink, even when there is none. Ink checking is only performed at power-on during initialization, and it will be reported that there is ink. As this error is not displayed, it can be checked on the EEPROM information printout in the error history section.

1.1.2 Status display via the BJ status monitor

The BJ status monitor window shows the printer's conditions and print-job progress. Print-jobs can be cancelled from this window.

(1) Main functions of the BJ status monitor

- 1) Show the printer's conditions and progress in real-time by means of graphics and messages.
- 2) Display error types and show recommended recovery methods.
- 3) Show the types of the BJ cartridges installed and the ink-out warnings of ink tanks by icon and name.
- 4) Abort the current print-job.

(2) Items displayed on the BJ status monitor

- 1) Printer designation
- 2) Document name
- 3) Printer conditions (including error codes and recommended recovery methods)
- 4) Date and time of print start
- 5) Progress status:
- 6) Number of pages printed
- 7) Print-job abortion
- 8) BJ cartridge identification (icons graphically display the types and positions of installed BJ cartridges, and the ink-out warnings of ink tanks)

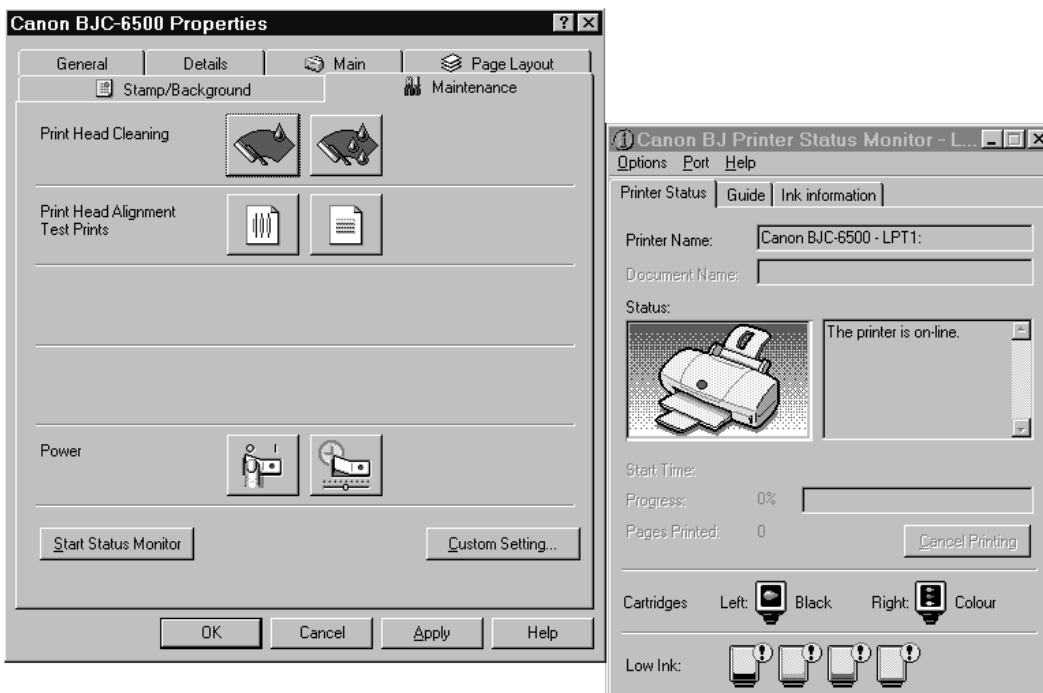

Figure 3-2 BJ Status Monitor (Sample)

1.2 Operations from the Computer

As this printer has no physical function selectors, function settings can be set by using the Canon printer driver.

1.2.1 Function settings using the printer driver

The printer driver's utility menu allows such operations and function settings as listed below. In the menu, you can also invoke a special custom menu by, while pressing the shift key, selecting Custom Settings.

- 1) Cleaning
 - 2) Head refreshing
 - 3) Nozzle check pattern printing (Test Print)
 - 4) Head position adjustment (Print Head Alignment)
 - 5) Printer power off
 - 6) Automatic power setting
 - 7) Launching the status monitor
 - 8) Custom settings
 - Enable ECP mode (disabled by default)
 - Enable high speed printing (enabled by default): Printer's response time (ACKNLG) is changed from 4 to 0.9 ms.
 - Enable pause-between-pages (disabled by default)
 - Enable pause-between-scanning (disabled by default)
 - Enable automatic head position adjustment following BJ cartridge replacement (disabled by default)
 - Manually conduct the print head position adjustment (disabled by default)
- <In the special custom menu (special-custom/service mode)>
- Economy cleaning (disabled by default): Cleaning operation at power up is omitted if the printer has been switched off for less than 72 hours. Enabling this function is useful for saving ink, especially when the printer's power is provided through the computer (possibility of nozzle clogging increases).
 - Smear control (enabled by default): When smear control is enabled, smearing of ink on paper due to paper-to-paper contact is prevented. Smear control is useful for high duty printing on normal plain paper or post cards. When smear control is disabled (with printed sheets collected directly following printing), throughput increases.

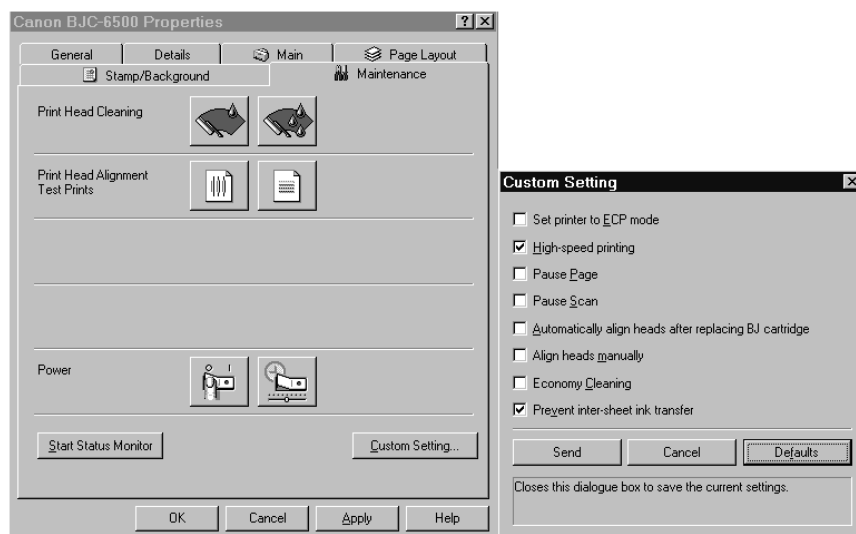

Figure 3-3 Printer Driver Utility (Sample)

1.3 Operations from the Printer

This printer has operations which can be performed independent of the computer. With the printer powered on, hold down the *RESUME* button and confirm the specified number of beeps for the desired action, and then release the *RESUME* button.

Operations	Number of beeps	Remarks
Cleaning	1 time	...
Nozzle check pattern printing	2 times	Prints one sheet and ends

1.3.1 Cleaning

With the printer powered on, hold down the *RESUME* button and after confirming one beep, release the *RESUME* button. The cleaning operation will start, cleaning both (right and left) print heads. If you want to clean only one print head, connect the printer to the computer, and perform the print-head cleaning from the computer using the printer driver utility.

1.3.2 Nozzle check pattern printing

With the printer powered on, hold down the *RESUME* button and after confirming two beeps, release the *RESUME* button. The nozzle check pattern printing will start, feeding a sheet, which must be of B5 size or larger from the auto sheet feeder and print a standard pattern using all nozzles of both installed BJ cartridges. If print defects are detected in the test print, perform print-head cleaning. If five or more cleaning operations fail to solve the problem, replace the BJ cartridge with a new one.



Use paper of B5 size or larger for the nozzle check pattern printing. If you use smaller paper, the platen may be smeared with ink.



To abort the nozzle check pattern printing, press the *POWER* button. The printer will switch itself off after ejecting the paper.

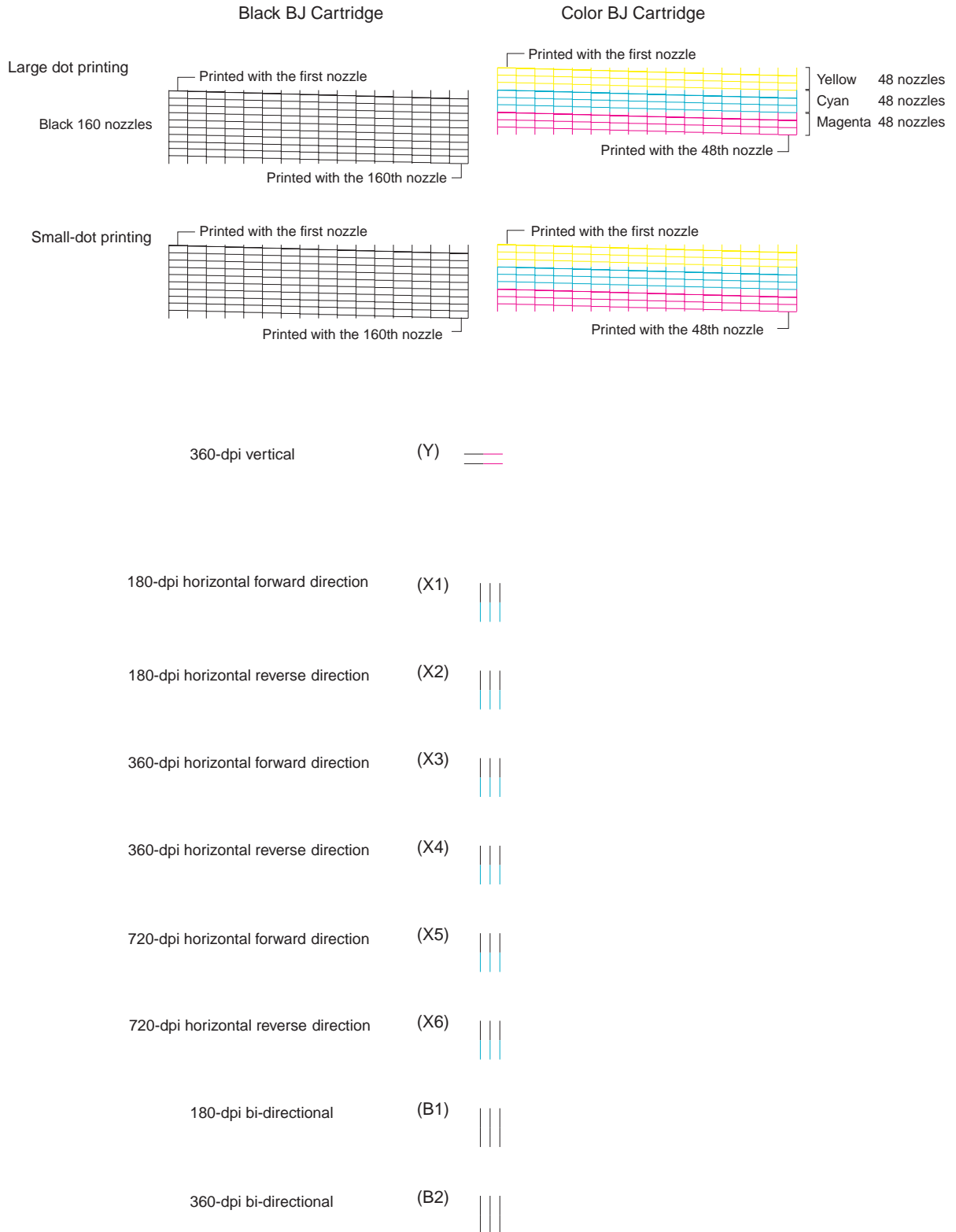

Figure 3-4 Nozzle Check Pattern Print (Sample for Black/Color Cartridge)

OPERATION

2. SERVICE FUNCTIONS

This printer has a service mode for service-related settings or performing test printing. The operator panel buttons are used to enter service mode.

2.1 Service Mode Operations

- 1) With the printer powered off, while pressing the *RESUME* button, press and hold the *POWER* button. The buzzer will sound once.
- 2) While holding down the *POWER* button, release the *RESUME* button. Press the *RESUME* button twice in succession, and then release the *POWER* button. (Each time the *RESUME* button is pushed, the buzzer will sound once.) The indicator will blink in green, and then light in green.
- 3) Select one of the following service mode functions by pressing the *RESUME* button the specified number of times.

Press	Indicator	Functions
0 times	Lights in Green	Service/factory test print
1 time	Lights in Orange	EEPROM information printing
2 times	Lights in Green	EEPROM initializing (reset to default settings, but model setting is not cleared)
3 times	Lights in Orange	Waste ink counter clear
4 times	Lights in Green	Model setting
5 times	Lights in Orange	Presence of ink information printing
6 times	Lights in Green	Print head position adjustment operations
7 times or more	Lights in Orange	Power off/Locking the Carriage

- 4) Execute the function you have selected by pressing the *POWER* button. The buzzer will sound once. The printer will switch off itself after performing the function.



Use the Black and Color BJ cartridges for the service/factory test printing. It is not possible to enter Service Mode without cartridges installed. (Also, the Photo and Color BJ cartridges cannot be used for service/factory test printing.) If you have changed the model setting, perform the service/factory test printing for confirmation.

2.3 Printing the EEPROM Information

The EEPROM stores such information as function settings, total sheets passed with the Black/Color or Photo/Color cartridges, total waste ink absorbed, and records the last three errors recoverable only by service personnel. The information stored in the EEPROM is printed out as a hexadecimal dump in the EEPROM information print. The EEPROM information is useful especially for knowing how heavily the printer has been used.

```

- EEPROM Information <Hex.> -
Address      +0 +1 +2 +3 +4 +5 +6 +7 +8 +9 +A +B +C +D +E +F
00000000    05 20 00 0A 00 00 B8 83 00 0C 9F 40 09 35 1C 28
00000010    00 00 00 00 2A 6A 51 A1 38 54 AA A0 1E 16 DA 3C
00000020    35 6C B7 AB 33 BC E9 71 32 DD 02 0C 00 00 00 00
00000030    14 00 0A 07 04 02 02 02 00 00 00 00 0A 80 00 00
00000040    04 90 00 08 00 00 00 44 00 00 00 44 00 00 00 44
00000050    00 00 00 00 00 00 04 44 00 00 00 00 00 00 02 B9
00000060    00 00 00 1D 00 58 00 1B 00 01 00 2F 00 06 00 00
00000070    00 00 00 00 00 00 00 08 00 00 00 08 00 00 00 08
00000080    00 00 00 72 00 00 00 2E 00 00 00 30 83 00 00 00
00000090    3C 00 00 10 10 0C 0C 08 0C 10 0C 0C 0C 10 0C 0C
000000A0    0C 04 00 08 00 0C 0C 00 FD 07 00 00 04 04 00 00
000000B0    00 00 00 00 04 04 00 00 00 00 00 00 00 00 00 00
000000C0    00 00 00 00 15 0B BB 19 35 1A D5 C6 13 0A 46 61
000000D0    04 19 57 AB 98 1A 72 13 00 45 93 6B 46 34 63 E3
000000E0    |35 36 30 30||35 31 30 30||35 31 30 30| FF FF FF F0
000000F0    00 00 |00 D6 67 7C| 73 FF 01 FF |FF FF FF FF FF FF
                Error record 1  Error record 2  Error record 3
    
```

Figure 3-6 EEPROM Information Print (Sample)

Error records are displayed in ASCII code for the last 3 errors, except for ROM/RAM errors, that are recoverable only by service personnel, with the most recent error first and the oldest error last.

Errors	Error code	ASCII code representation
EEPROM error	6800	36 38 30 30
Home position error	5100	35 31 30 30
Temperature sensor error	5400	35 34 30 30
Waste ink full error	5B00	35 42 30 30
Head temperature error	5200	35 32 30 30
Head temperature sensor error	5200	35 32 30 30
Cartridge displaced error	5600	35 36 30 30
Ink sensor error	5910	35 39 31 30
ASF sensor error	5700	35 37 30 30

2.4 Resetting the EEPROM

The EEPROM stores such information as function settings, total sheets passed with the Black/Color or Photo/Color cartridges, total waste ink absorbed, and the last three errors recoverable only by service personnel. Because the waste ink full error is based on the data of the total waste ink absorbed as stored in the EEPROM, the Waste Ink Counter must be cleared whenever the waste ink absorber has been replaced. If the control board has been replaced, the new EEPROM must also be initialized and the waste ink absorber replaced.

2.5 Setting the Model

The control board of this printer is a common component for different printers. If you have replaced the control board, it is necessary to set the model setting as initial information. After selecting the model, by pressing the *POWER* button, the selection will be validated. (Each time the *RESUME* button is pressed, the beeper will sound once.)

Times	Indicator	Model
0 times	Lights in Green	BJ F6100
1 time	Lights in Orange	BJC-6500
2 times or more	...	BJC-XXXX (reserved for OEM)

After setting the model, perform the service/factory test printing for confirmation.

2.6 Checking the Presence of Ink

When this function is enabled, the printer will check for ink in the ink storage chamber, and print out the results.

This function can be used to confirm correct operation of the Ink Sensor.

- (1) Install an ink tank (with an empty ink storage chamber) into the Color BJ cartridge.
- (2) Select this function, and print out the results.
- (3) Confirm that a value of "0" is returned for the empty ink tank.

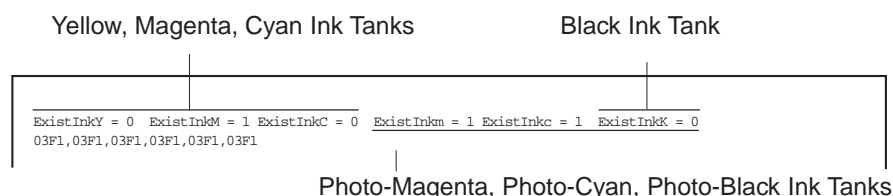

Figure 3-7 Checking for Presence of Ink

2.7 Conducting the Print Head Position Adjustment

The print head position adjustment can be performed off-line (without being connected to a computer). The printer will perform the print head position adjustment in the same way as if the user initiated the adjustment from the computer via the printer driver utility.

2.8 Powering Off and Locking the Carriage

When this function is enabled, regardless of whether BJ cartridges are installed in the carriage, the printer will move the carriage to the home position and, after locking the carriage, power off. When transporting the printer for service when no BJ cartridge is present, in order to lock the carriage, this function can be used.

- (1) Enter Service Mode.
- (2) Press the *RESUME* button 7 times.
- (3) Open the front cover and remove the BJ cartridge(s).
- (4) Press the *POWER* button.

This page intentionally left blank

Part 4

TROUBLE SHOOTING

Page	
4 - 1	1. TROUBLESHOOTING BY DISPLAYED ERRORS
4 - 1	1.1 Initial Flowchart
4 - 5	1.2 Error Indications (Indicator, Beeper, Error Code)
4 - 6	1.3 Troubleshooting by Errors
4 -19	2. TROUBLESHOOTING BY SYMPTOMS
4 -19	2.1 Troubleshooting by Symptoms

1. TROUBLESHOOTING BY DISPLAYED ERRORS

1.1 Initial Flowchart

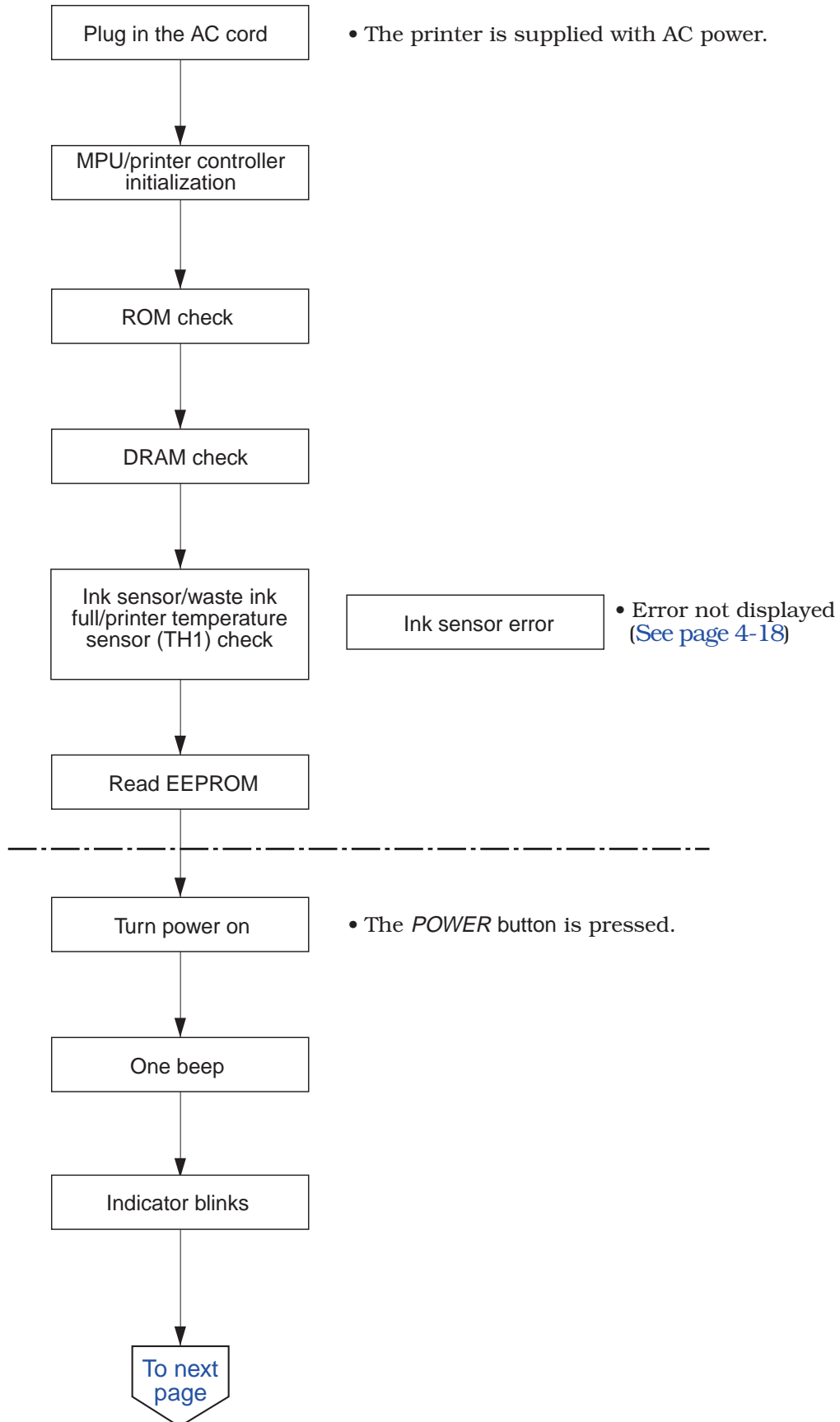

TROUBLE SHOOTING

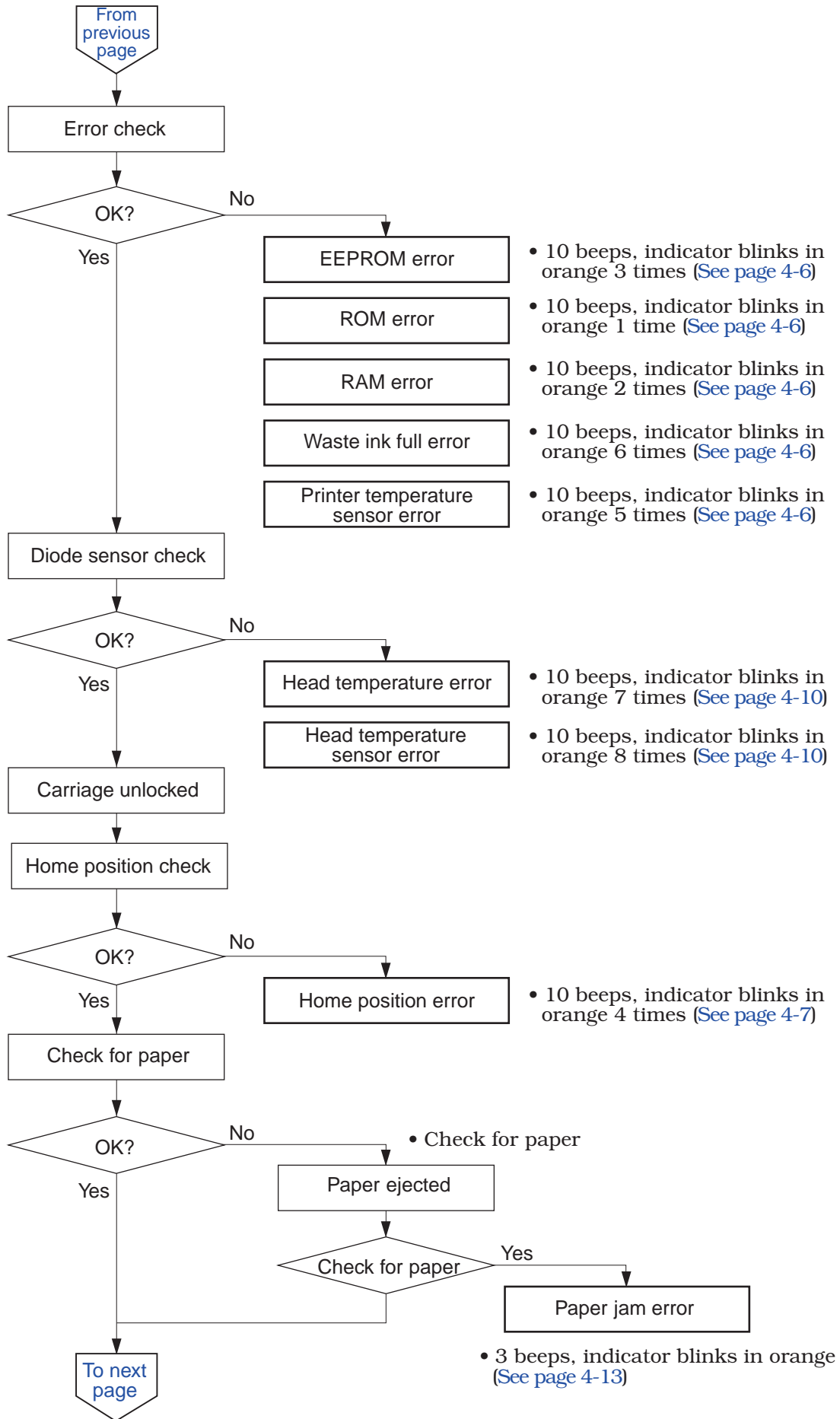

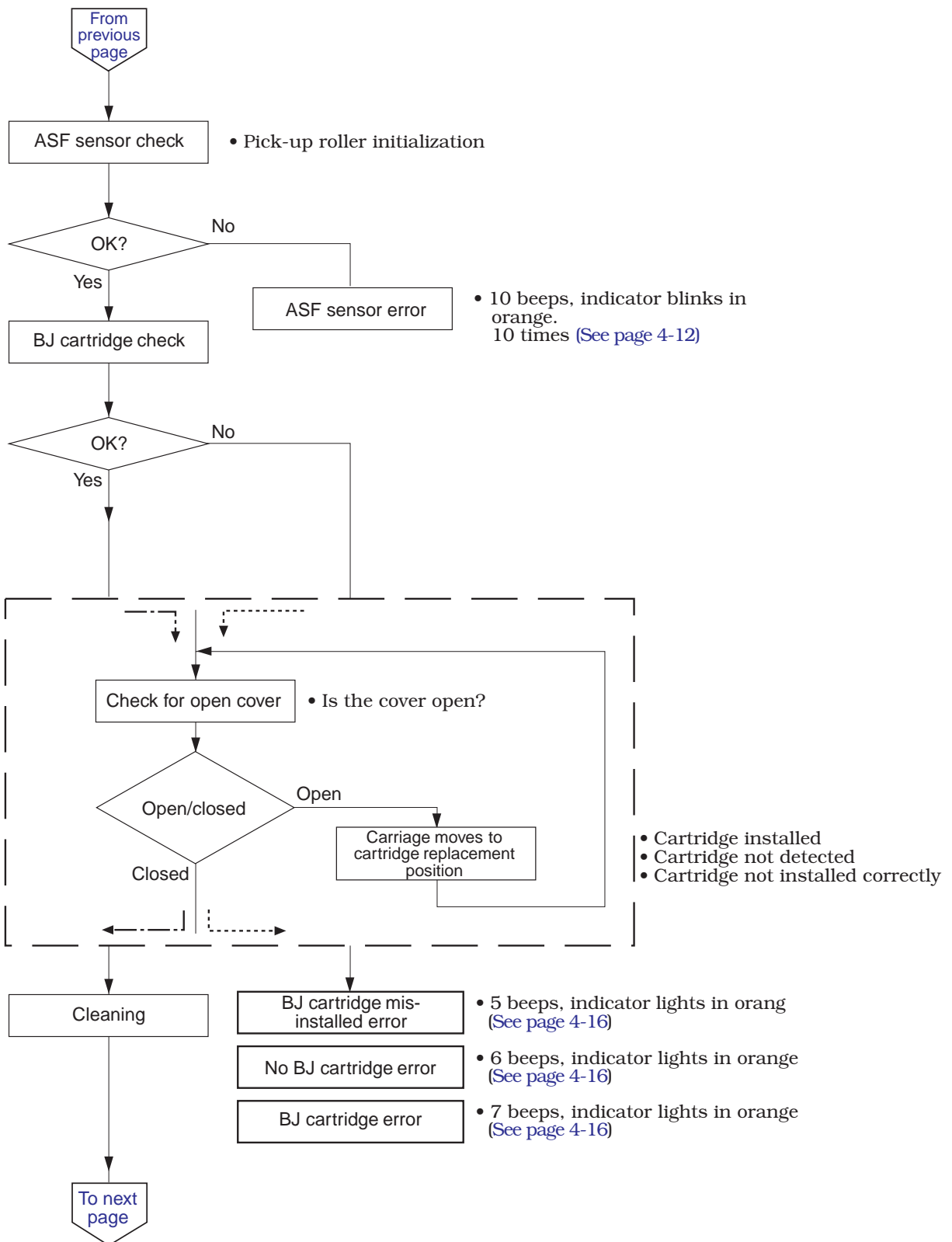

TROUBLE SHOOTING

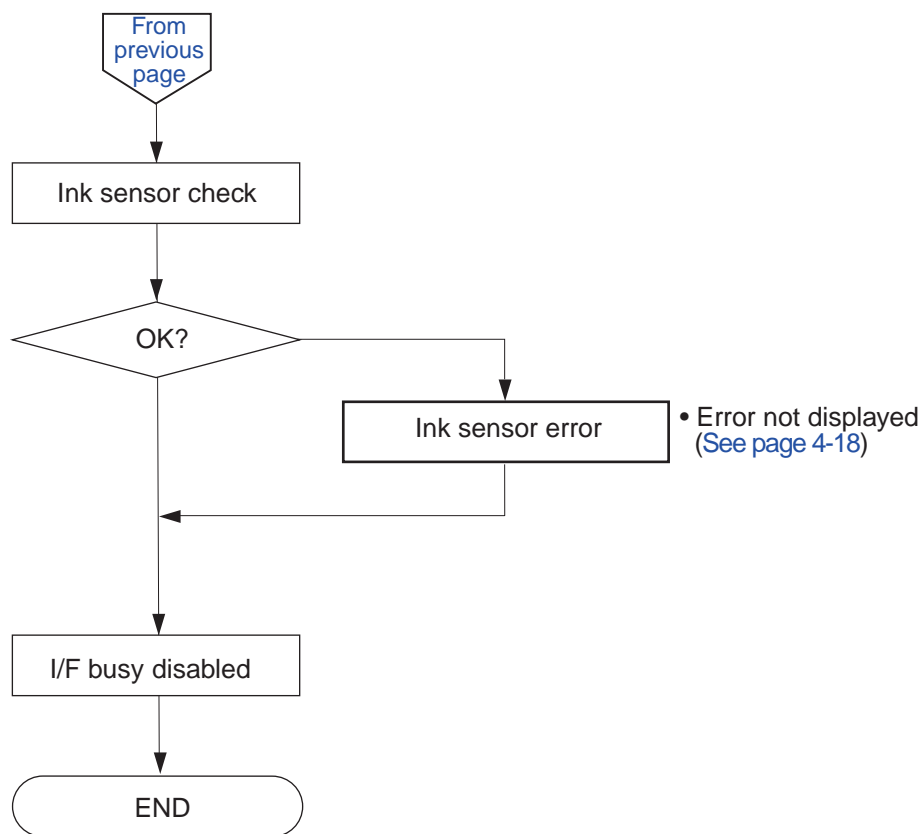

1.2 Error Indications (Indicator, Beeper, Error Code)

TABLE 4-1 ERROR INDICATIONS

Errors	Indicator	Beeps	Error code	Reference page
[Recoverable by user]				
Paper feed error	Lights in Orange	2 times		Page 4-13
Paper jam error	Lights in Orange	3 times		Page 4-13
Ink out error	Lights in Orange	4 times		Page 4-15
BJ cartridge mis-installed error	Lights in Orange	5 times		Page 4-16
No BJ cartridge error	Lights in Orange	6 times		Page 4-16
BJ cartridge error	Lights in Orange	7 times		Page 4-16
Waste ink warning error	Lights in Orange	8 times		Page 4-6
Head position adjustment error	Lights in Orange	9 times		Page 4-17
[Unrecoverable by user]				
ROM error	Blinks in Orange 1 time	10 times		Page 4-6
RAM error	Blinks in Orange 2 times	10 times		Page 4-6
EEPROM error	Blinks in Orange 3 times	10 times	6800	Page 4-6
Home position error	Blinks in Orange 4 times	10 times	5100	Page 4-7
Printer Temperature sensor error	Blinks in Orange 5 times	10 times	5400	Page 4-6
Waste ink full error	Blinks in Orange 6 times	10 times	5B00	Page 4-6
Head temperature error	Blinks in Orange 7 times	10 times	5200	Page 4-10
Head temperature sensor error	Blinks in Orange 8 times	10 times	5200	Page 4-10
Cartridge displaced error	Blinks in Orange 9 times	10 times	5600	Page 4-11
ASF sensor error	Blinks in Orange 10 times	10 times	5700	Page 4-12
[Internal errors]				
Ink sensor error	No indication	None	5910	Page 4-18

Note: Internal errors are not displayed, but can be checked by printing the EEPROM information (Page 3-10).

*1 The Waste Ink Warning error can be recovered by pressing the *RESUME* button.

1.3 Troubleshooting by Errors

1. ROM Error

<Cause> ROM cannot be read during initialization.

<Suspected parts> Control ROM

<Measure> Replace the ROM or control board.

2. RAM Error

<Cause> RAM cannot be read or written.

<Suspected parts> DRAM, printer controller

<Measure> Replace the control board.

3. EEPROM Error

<Cause> EEPROM cannot be written.

<Suspected parts> EEPROM, printer controller

<Measure> Replace the control board.



Error indications may fail if the ROM or RAM error occurs.

4. Printer Temperature Sensor Error

<Cause> The thermistor is defective.

<Suspected parts> Thermistor (TH1)

<Measure> Replace the control board.

5. Waste Ink Full Error/Waste Ink Warning

<Cause> The calculated amount of waste ink absorbed is 100% or 95% of the capacity of the waste ink absorber.

<Suspected parts> Waste ink absorber, control board

<Measure> 1. Reset the EEPROM/replace the waste ink absorber.

2. Replace the control board.

6. Home Position Error

<Cause> The home position sensor fails to detect the home position.

<Suspected parts> Home position sensor, carriage motor, paper feed motor, control board, carriage ribbon cable, carriage board, and DC power supply cable

<Measure>

Visual check

- Check for paper jams, carriage belt wear/degradation/displacement, bent carriage guide frame, and guide shaft damage/bending.
- Move the carriage by hand and check for smoothness and unusual noise.
- Is the carriage ribbon cable free of creasing?

OK?

No

Repair or replace faulty part

Open the cover and switch on

Check the carriage for smooth motion

Visually check the carriage's motion.

OK?

No

Check the carriage motor

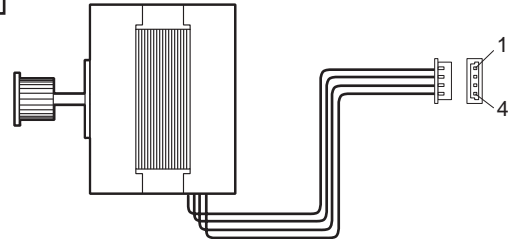

Measurement points	Normal value
CN402 Pin No. 1-3	Approx. 3Ω
Pin No. 2-4	

Disconnect the carriage motor cable from the control board before checking.

OK?

No

Replace the carriage motor

To page 4-9 (1)

To next page

TROUBLE SHOOTING

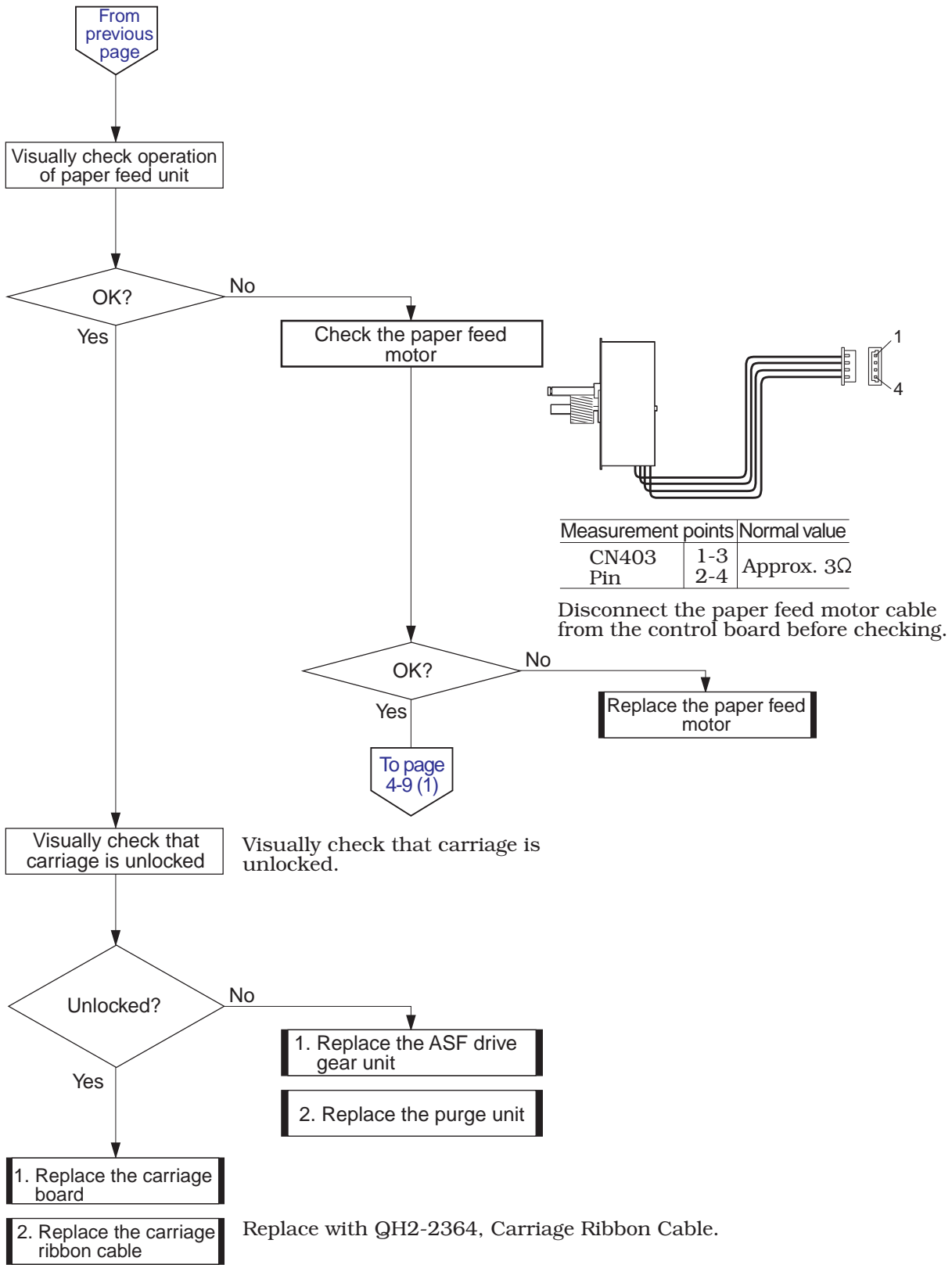

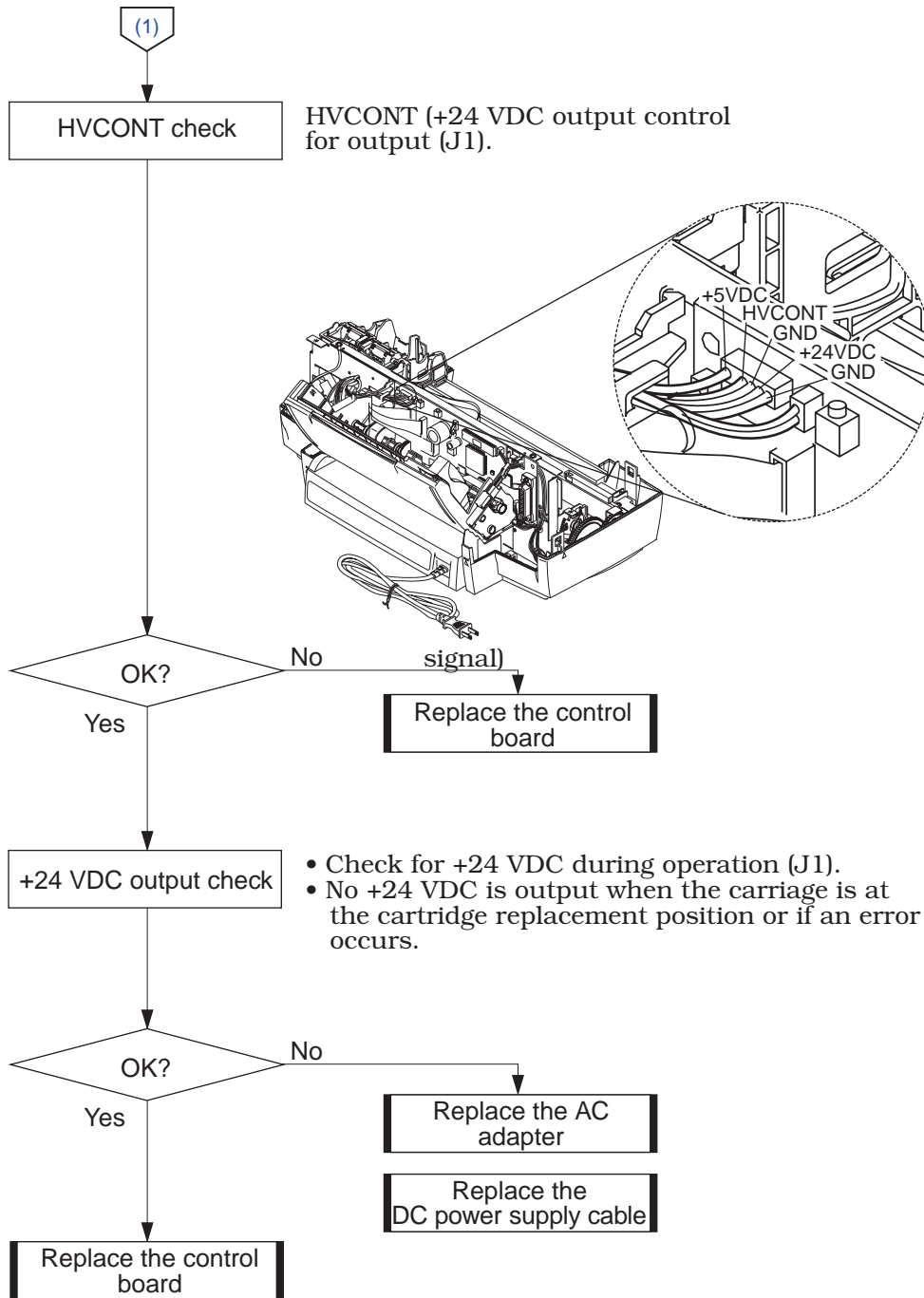

TROUBLE SHOOTING

7. Head Temperature Error / Head Temperature Sensor Error

<Cause> The print head is too hot.
Even with power turned off, head temperature doesn't drop.

<Suspected parts> BJ cartridge, control board, empty ink tank.

<Measure>

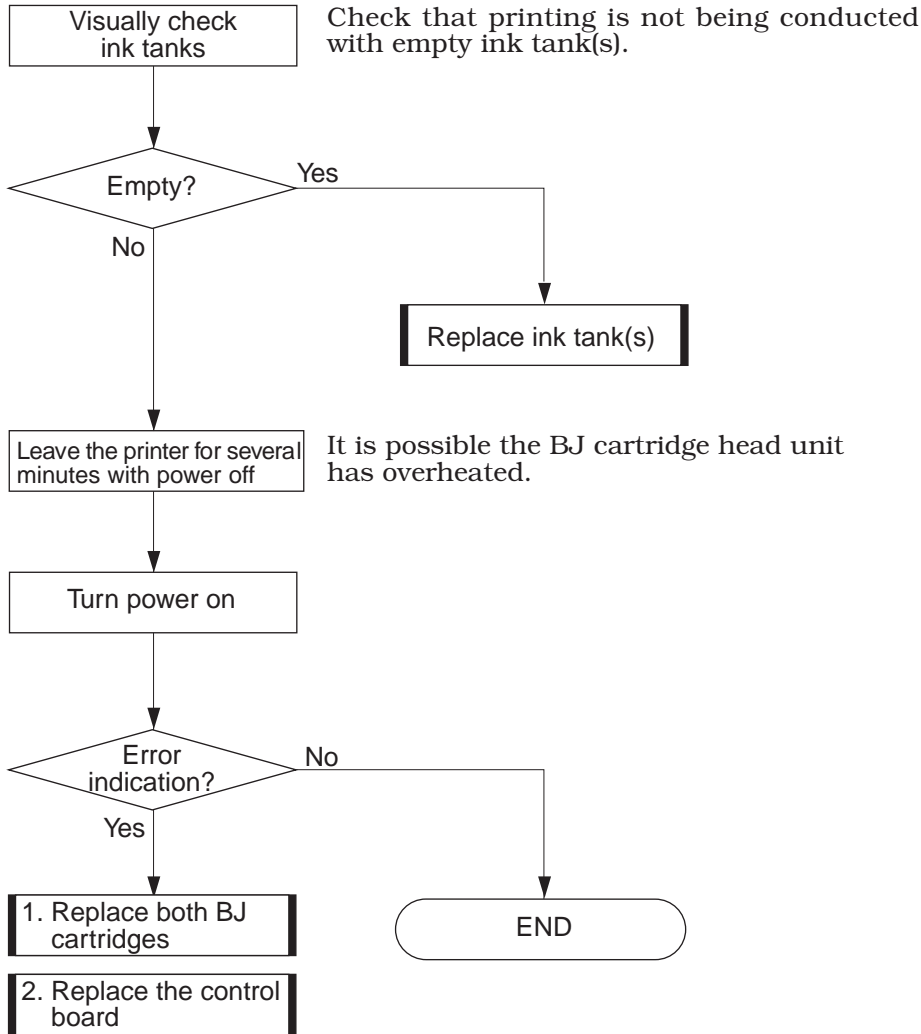

8. Cartridge Displaced Error

<Cause> The BJ cartridge is out of position outside the cartridge replacement position.

<Suspected parts> BJ cartridge, control board, carriage board, carriage ribbon cable

<Measure>

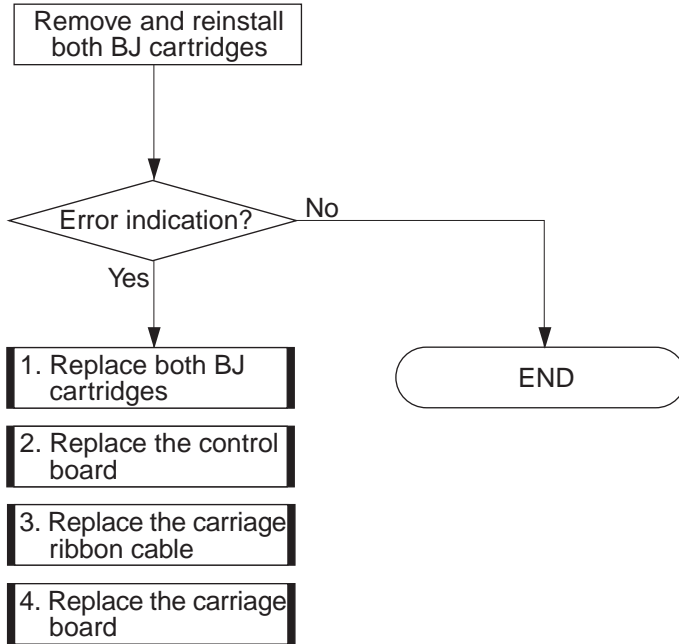

TROUBLE SHOOTING

10. ASF Sensor Error

<Cause> Pick-up roller doesn't turn.
LF roller drive switching isn't conducted.
<Suspected parts> ASF drive gear unit, control board
faulty ASF gear position adjustment,
pick-up roller

<Measure>

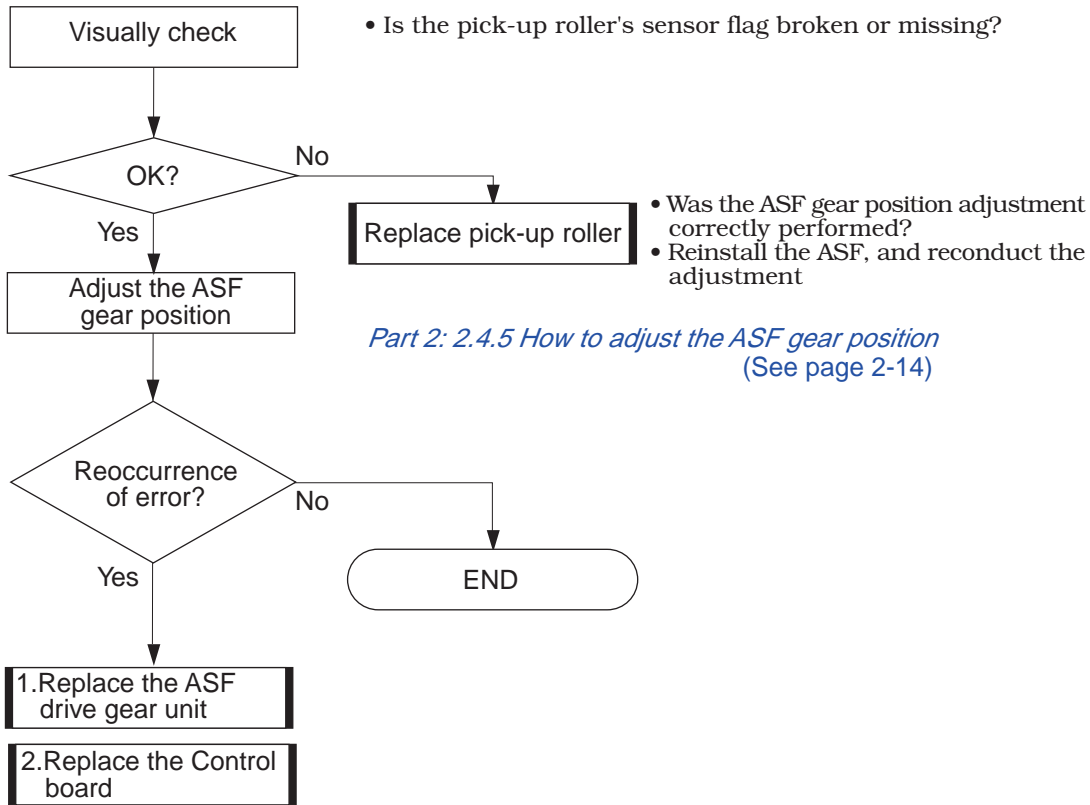

9. Paper Feed Error/Paper Jam Error

<Cause> Paper feed operation fails to feed paper.
 Paper eject operation fails to eject paper.
<Suspected parts> Paper feed section, paper end sensor, control board

<Measure>

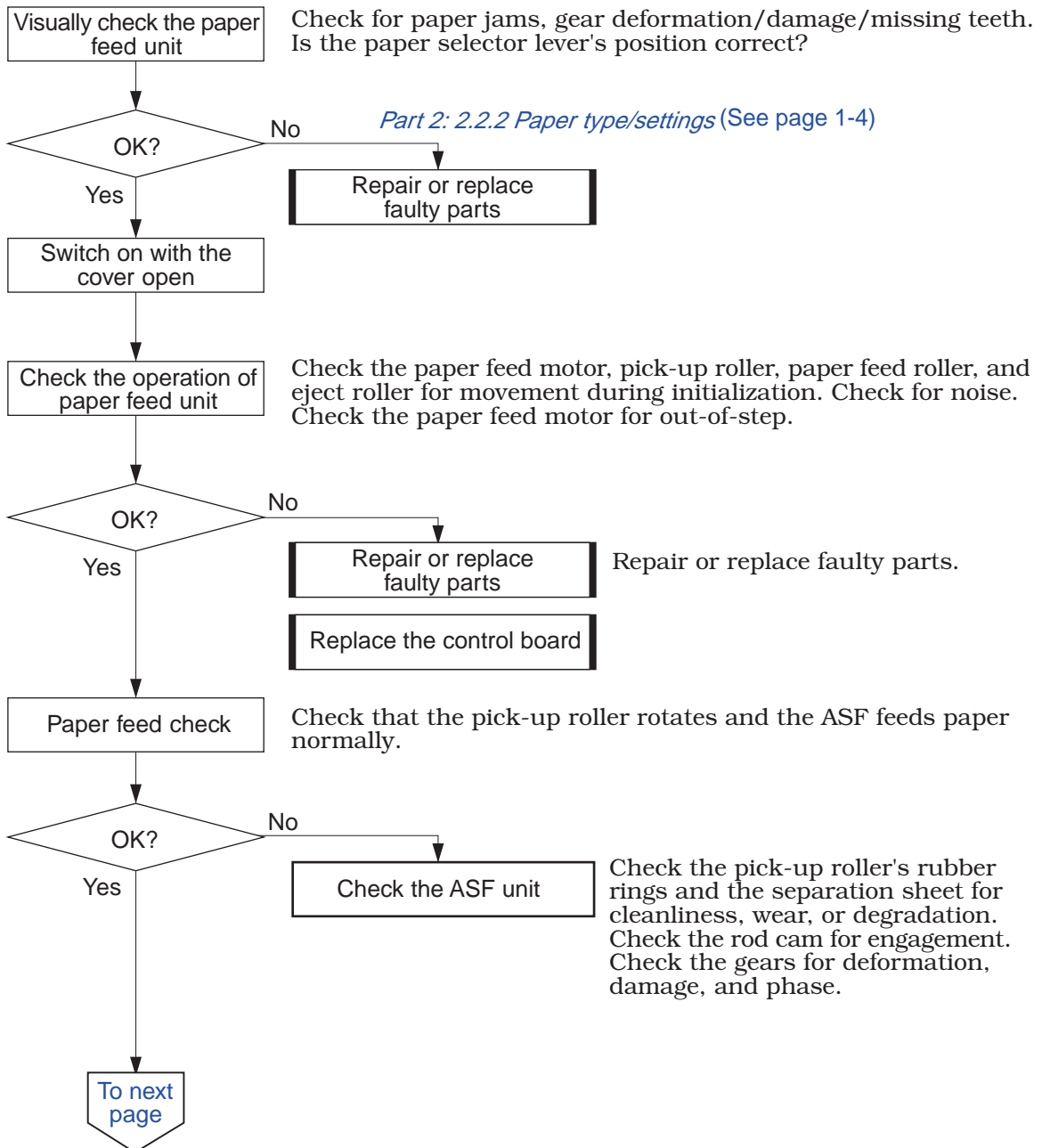

TROUBLE SHOOTING

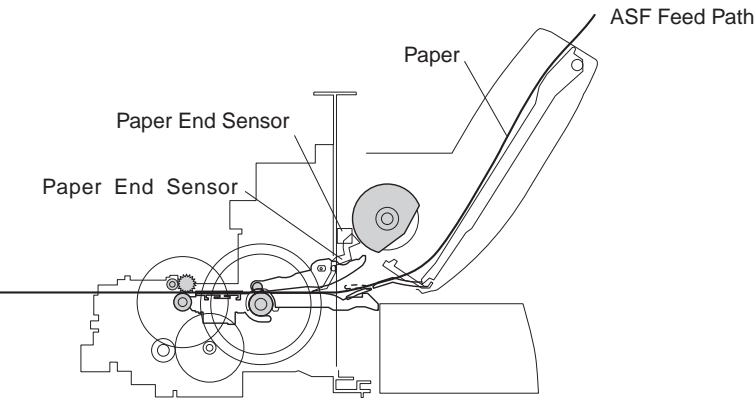
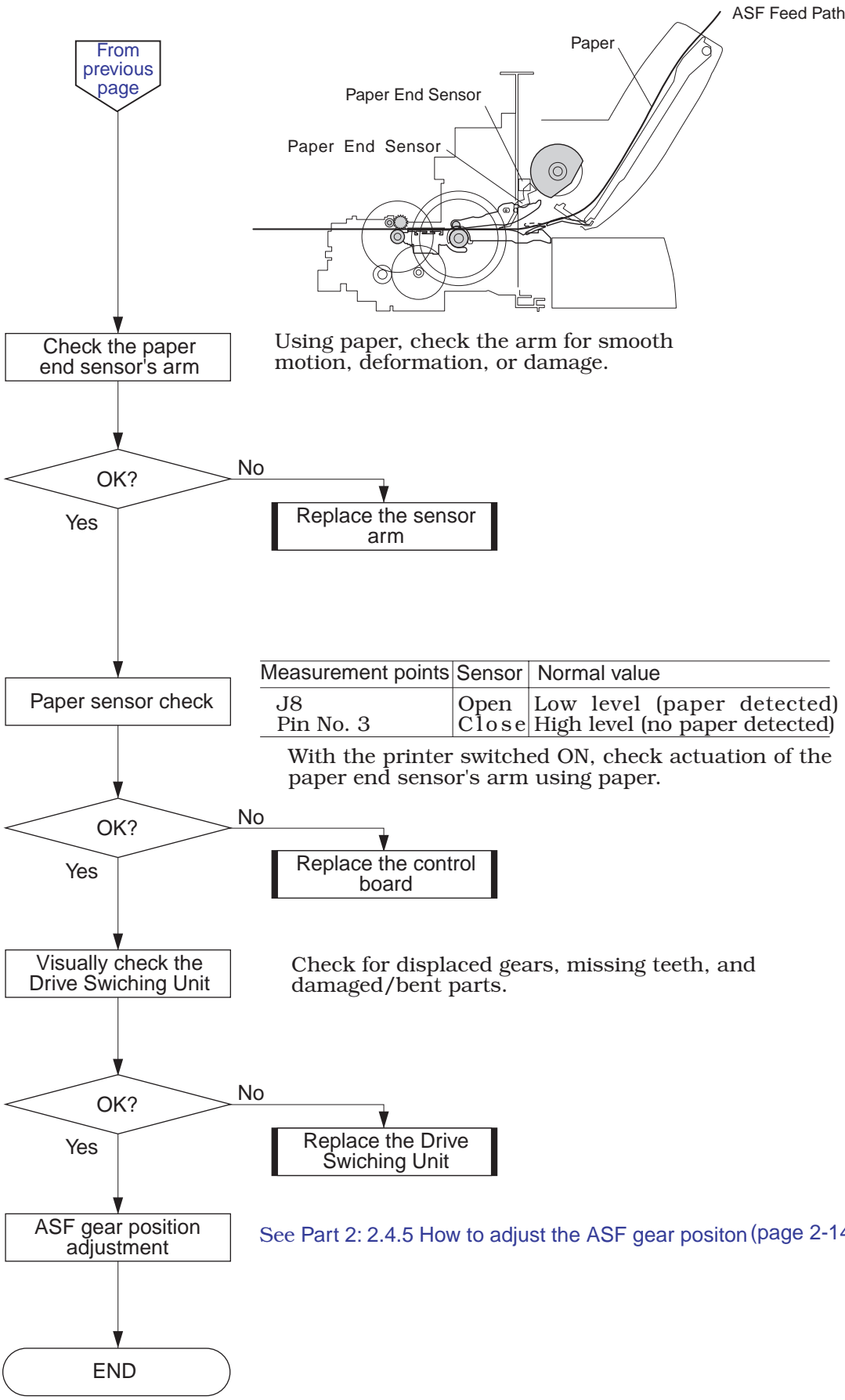

Using paper, check the arm for smooth motion, deformation, or damage.

Measurement points	Sensor	Normal value
J8	Open	Low level (paper detected)
Pin No. 3	Close	High level (no paper detected)

With the printer switched ON, check actuation of the paper end sensor's arm using paper.

Check for displaced gears, missing teeth, and damaged/bent parts.

See Part 2: 2.4.5 How to adjust the ASF gear position (page 2-14).

11. Ink Out Error

<Cause> The ink tank is empty.
EEPROM is defective.
<Suspected parts> Ink tank, EEPROM

<Measure>

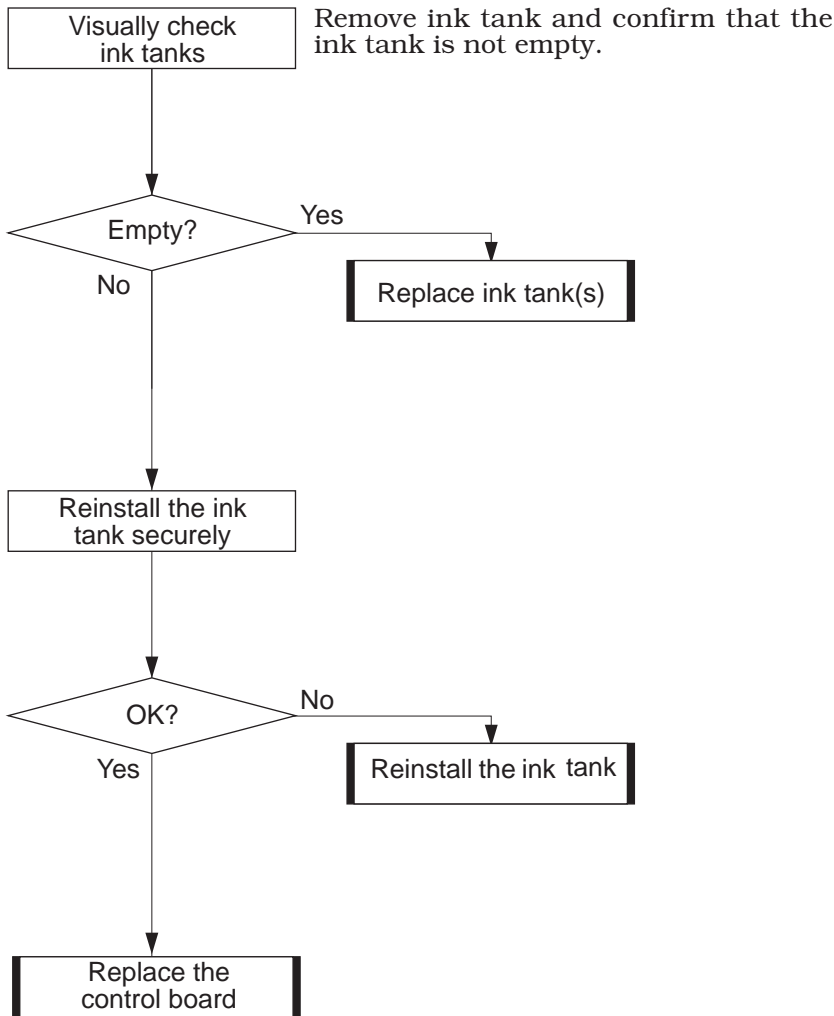

TROUBLE SHOOTING

12. BJ Cartridge Error/BJ Cartridge Mis-installed Error/No BJ Cartridge Error

<Cause>

- BJ cartridge not detected.
- BJ cartridge not installed.
- BJ Scanner cartridge combination wrong.

<Suspected parts> BJ cartridges, carriage board, control board, carriage ribbon cable, contacts between BJ cartridge and carriage

<Measure>

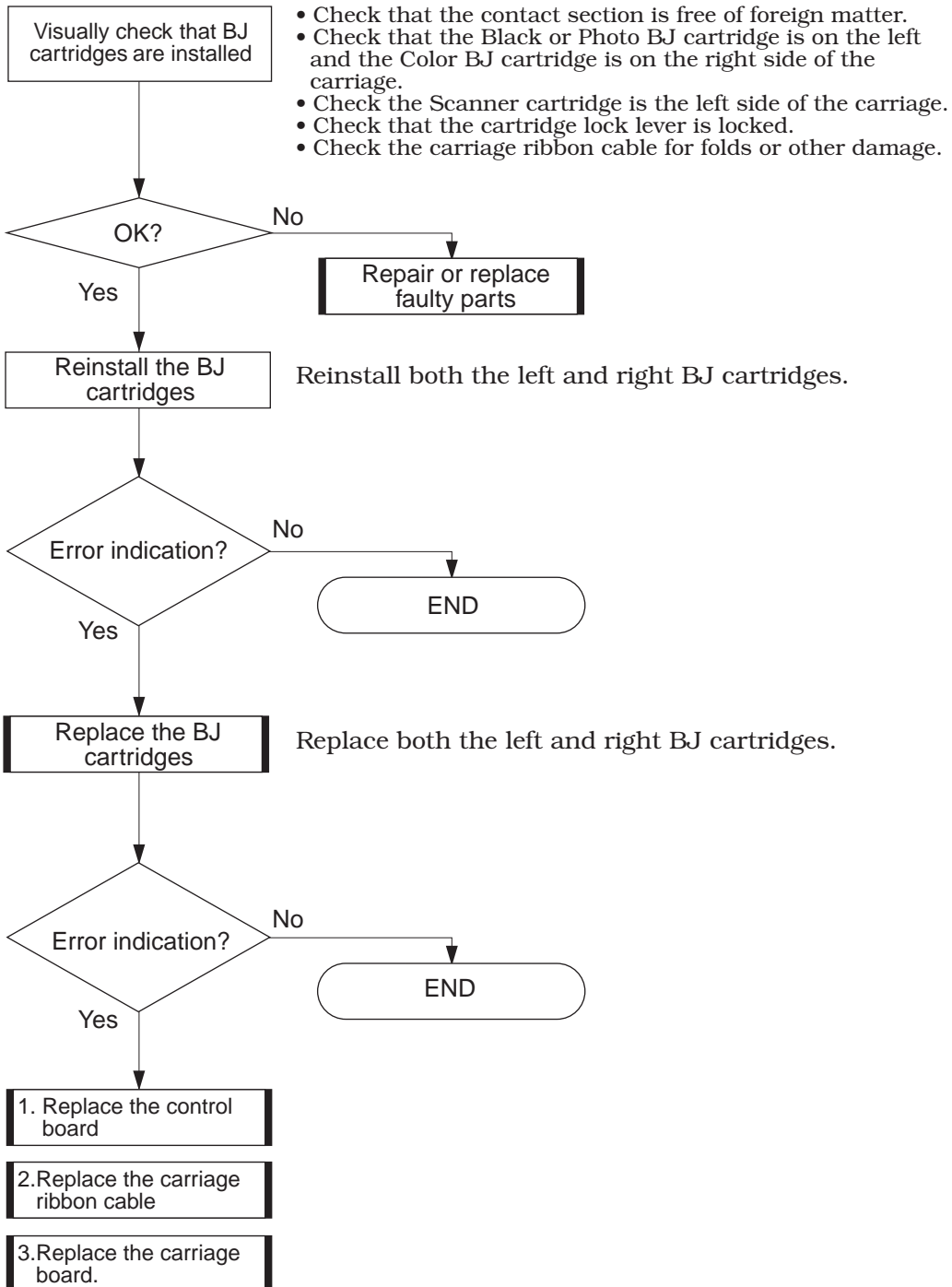

13. Head Position Adjustment Error

<Cause> The head position adjustment has failed.

<Suspected parts> BJ cartridge, ink tank, print position sensor, control board, carriage ribbon cable

<Measure>

Is the automatic head position adjustment pattern correctly printed?

OK?

No

Yes

1. Conduct cleaning
2. Replace the ink tanks
3. Replace the BJ cartridges

- Black/cyan ink tank
- Black/Color BJ cartridge

Print position sensor check

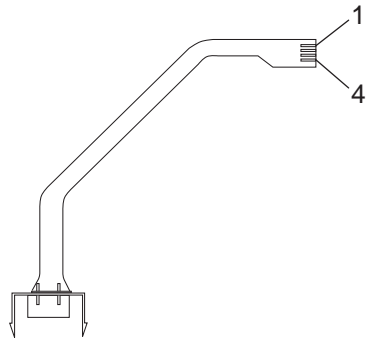

Measurement points	Sensor	Normal value
Pin No. 1- 2	...	Approx. 2.0V
Pin No. 2- 3	...	Approx. 2.0V

OK?

No

Yes

Replace the print position sensor

1. Replace the carriage board
2. Replace the control board
3. Replace the carriage ribbon cable

- Replace with QH2-2364 (Carriage Ribbon Cable)

TROUBLE SHOOTING

14 Ink Sensor Error

<Cause> Ink sensor check does not detect ink out.
<Suspected parts> Ink sensor, control board, ink tank

<Measure>

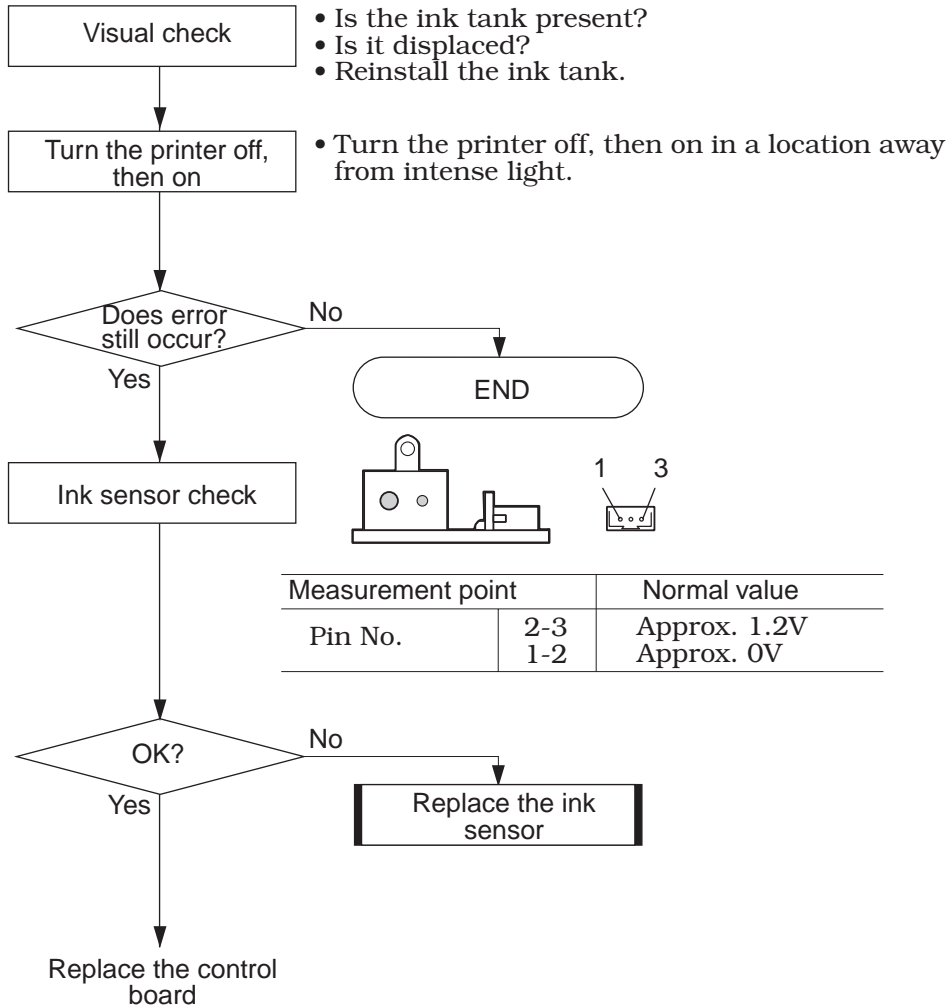

2. TROUBLESHOOTING BY SYMPTOMS

2.1 Troubleshooting by Symptoms

1. Power Does Not Turn On.

<Symptoms> Pressing the *POWER* button fails to switch on the printer.

Pressing the *POWER* button does not start initialization.

<Cause> Defective AC adapter, control board, or DC power supply cable

<Measure>

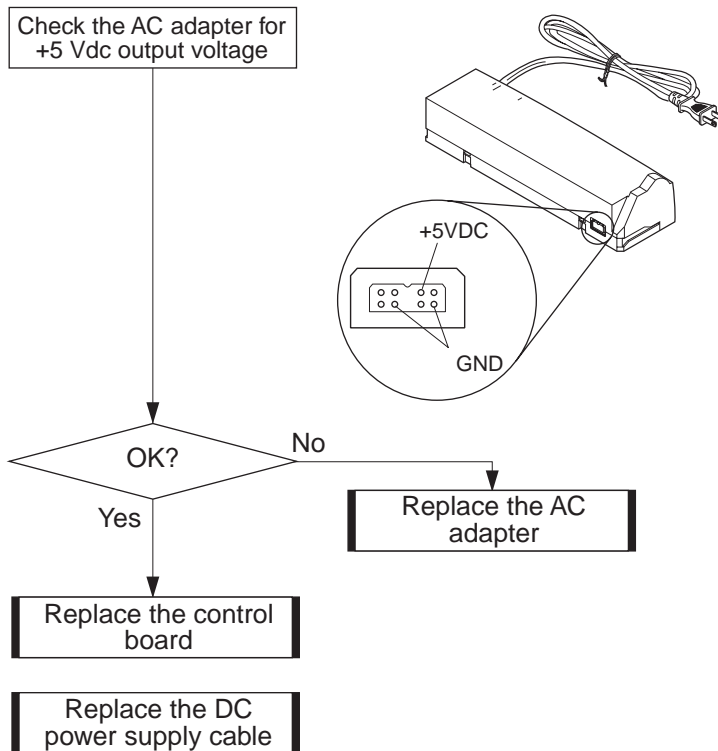

TROUBLE SHOOTING

2. Faulty Printing: No Printing

<Symptoms> No prints
Partial prints
No prints for some colors

<Cause> The ink tank, BJ cartridge, or purge unit is defective, the orange cap and/or tape is affixed to the head unit.

<Measure>

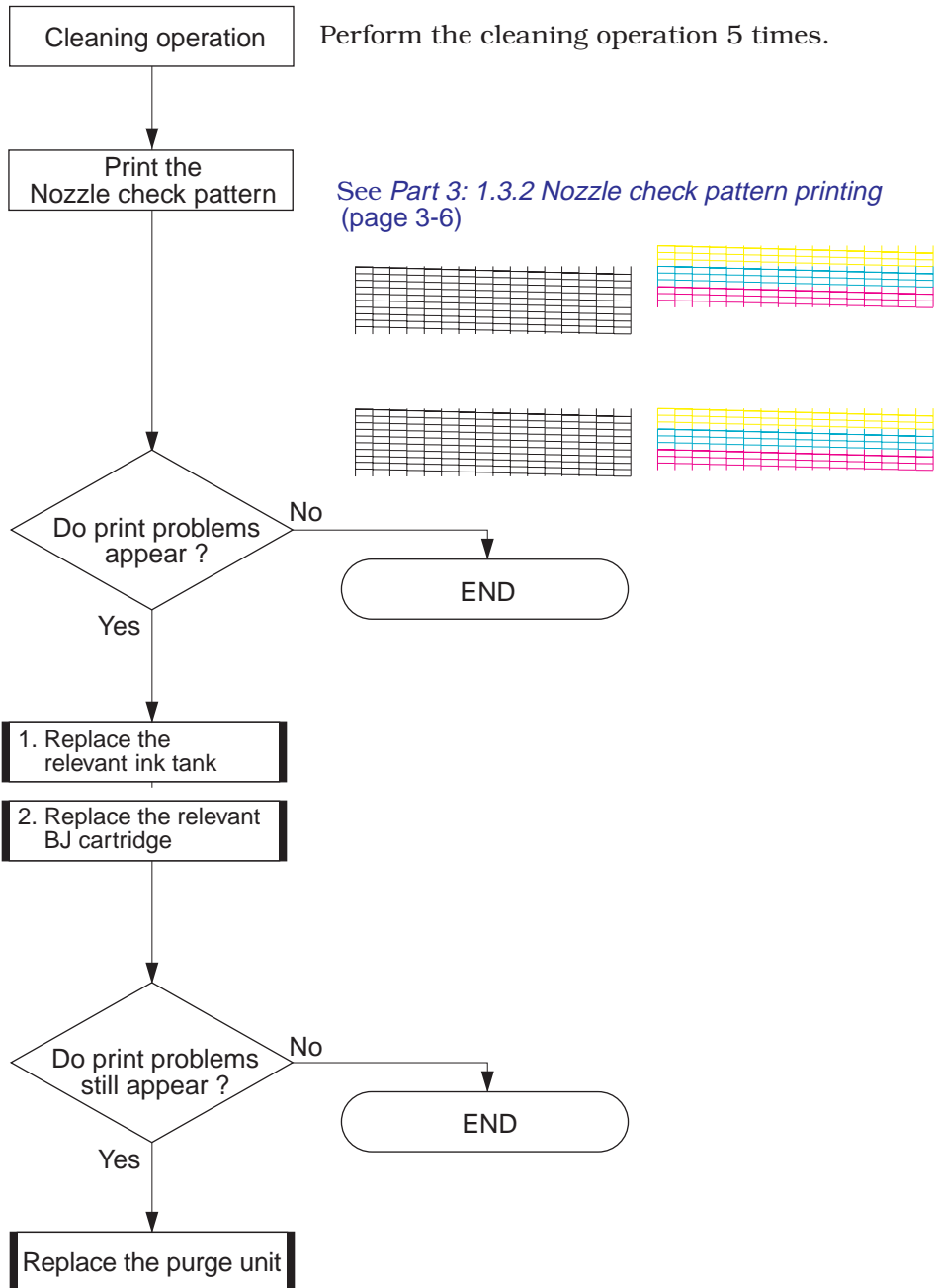

3. Faulty Printing: Blank Lines Appear

<Symptoms> Blurred prints
Blank lines
Specific dot missing

<Cause> The BJ cartridge(s), BJ cartridge contacts, carriage ribbon cable, purge unit, control board or carriage board is defective.

<Measure>

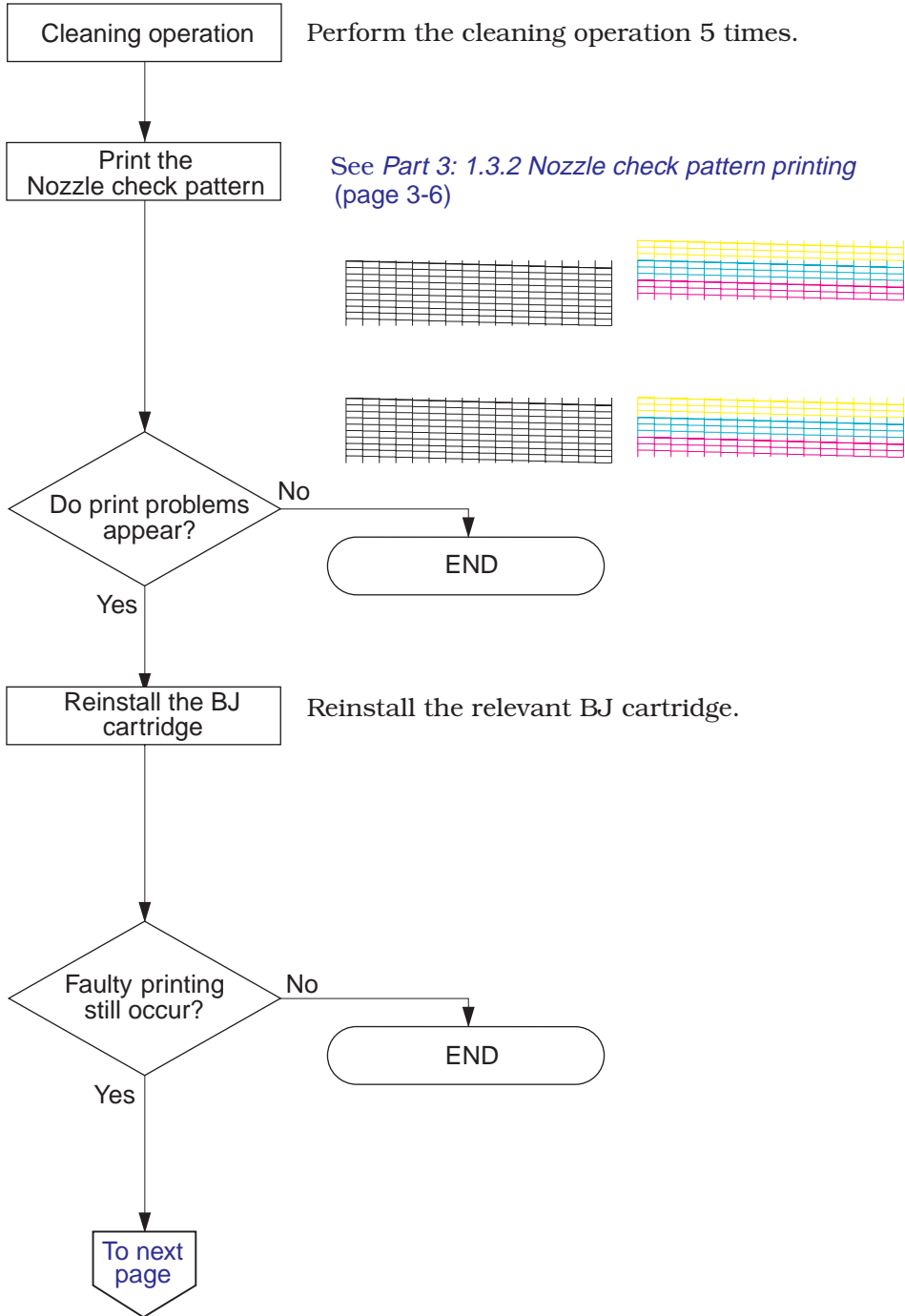

TROUBLE SHOOTING

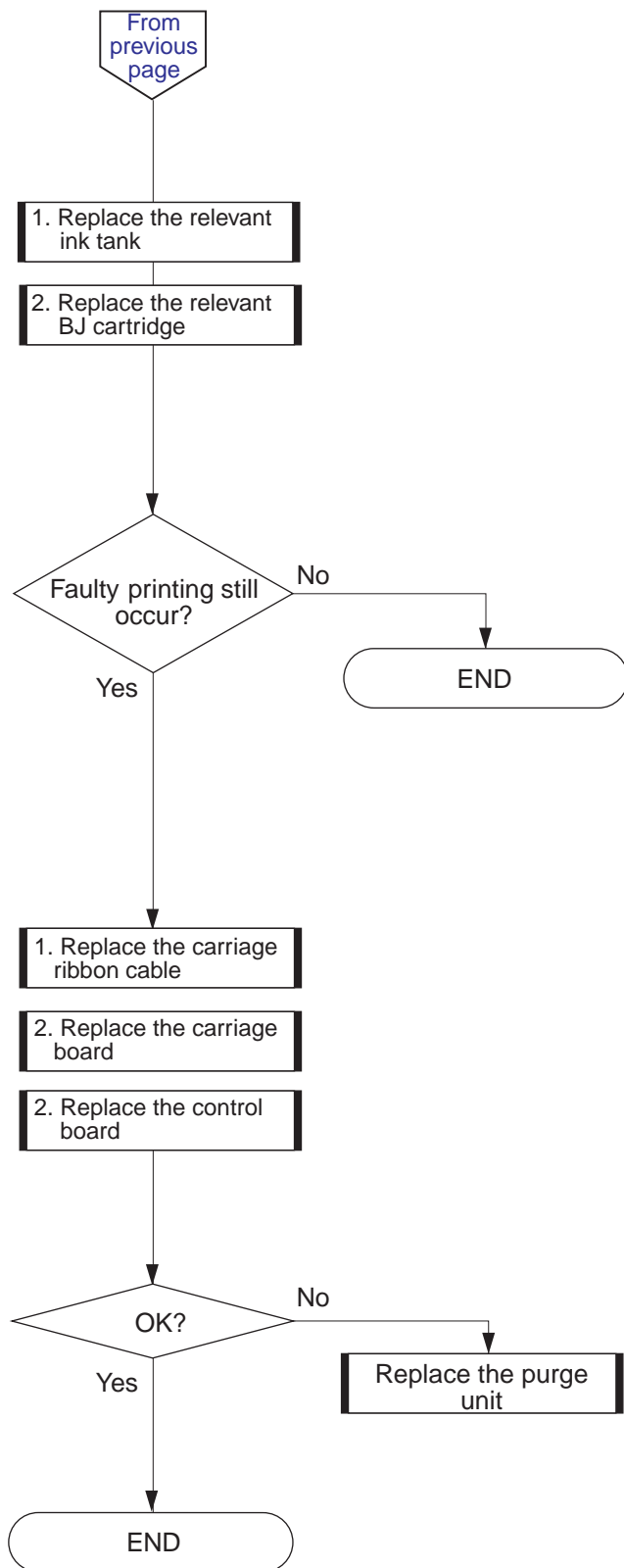

4. Faulty Printing: Other

Symptoms	Check to see if	Measure
Paper gets dirty	The platen is contaminated with ink mist.	Wipe clean with a damp cloth.
	The paper feed unit is contaminated with ink (paper is contaminated before reaching the platen).	Disassemble the paper feed unit and wipe clean with a damp cloth. Perform test paper feeding several times.
Spur marks appear	The tips of the spurs are deformed.	Replace the spur unit.
Vertical misalignment	The paper thickness selector is wrongly set (positioned).	Correct the setting.
	The printed nozzle check pattern has mis-alignment.	Readjust printing position.

5. Ink Out Resulting in no Error

<Symptoms> Ink out results in no error.

<Cause> The ink tank is empty, or the control board or ink sensor is defective.

<Measure>

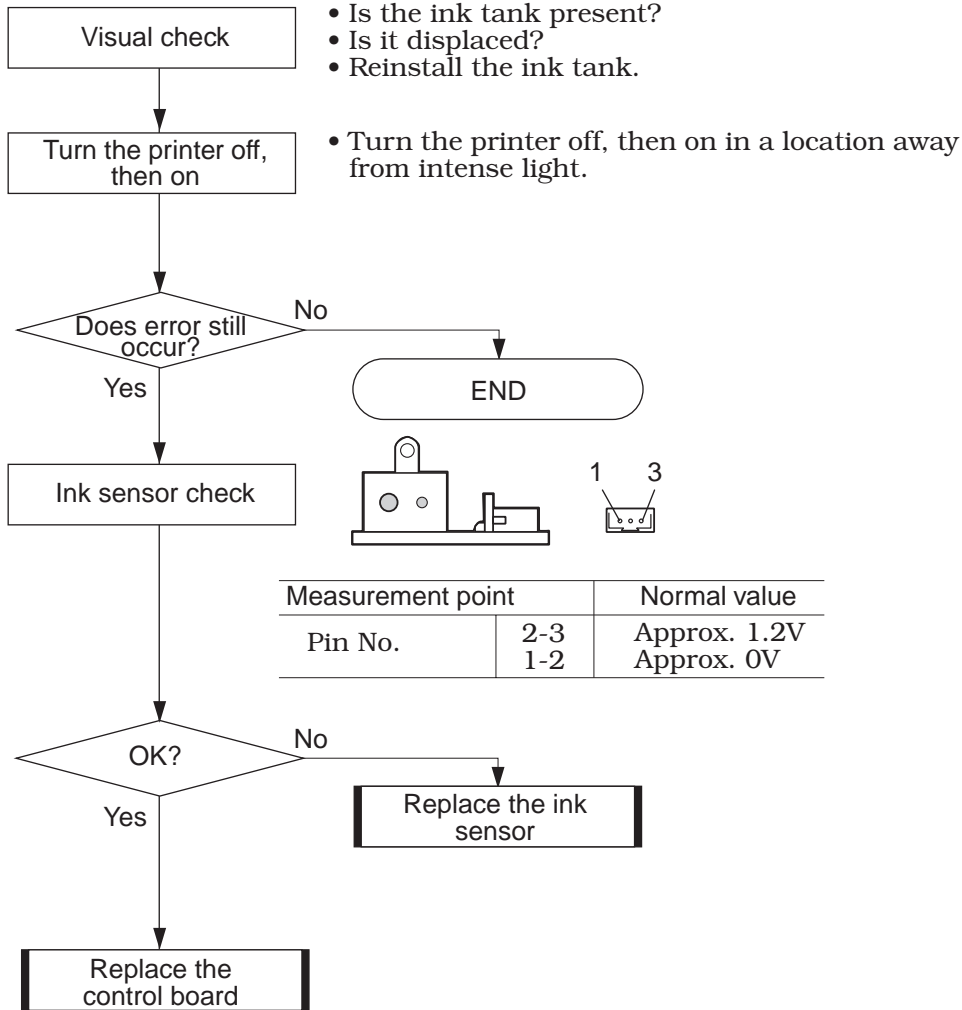

Part 5

REFERENCE

Page	
5 - 1	1. TECHNICAL REFERENCE
5 - 1	1.1 Functions of the Paper Feed Unit
5 - 2	1.2 Construction of the Paper Feed Unit
5 - 3	1.3 Form Alignment Function
5 - 4	1.4 Transmission Gear Unit
5 - 5	1.5 Detection with Sensors
5 - 5	1.6 BJ Cartridge Identification
5 - 6	2. CONNECTOR POSITIONS AND PIN ASSIGNMENT
5 - 6	2.1 Control Board
5 -11	2.2 Carriage Board
5 -14	2.3 BJ Cartridge
5 -15	2.4 Scanner Cartridge (Optional)
5 -16	2.5 AC Adapter
5 -16	2.6 DC Power Supply Cable
5 -17	2.7 Carriage Motor
5 -17	2.8 Paper Feed Motor
5 -17	2.9 Paper End Sensor
5 -18	2.10 Ink Sensor
5 -18	2.11 Print Position Sensor
5 -18	2.12 Pump Sensor
5 -19	3. INSTALLATION
5 -19	3.1 Installation
5 -19	3.2 Installation Procedures
5 -20	4. MISCELLANEOUS
5 -20	4.1 Similarities and Differences to the BJC-6100

1. TECHNICAL REFERENCE

1.1 Functions of the Paper Feed Unit

The paper feeding function of this printer is to feed the print media from the Auto Sheet Feeder (ASF) through to the print start position.

The ASF is driven by the paper feed motor, and automatically feeds the print media.

When the print media has been detected by the photo-interrupter type paper end sensor, it is fed to the print start position on the platen via the paper feed rollers.

If print media is fed, but not detected by the paper end sensor, a paper feed error will occur.

Also, after the paper end sensor has detected the paper and measured the amount of paper fed, if this amount is low, the printer will utilize the paper feed assistance function to reattempt paper feeding.

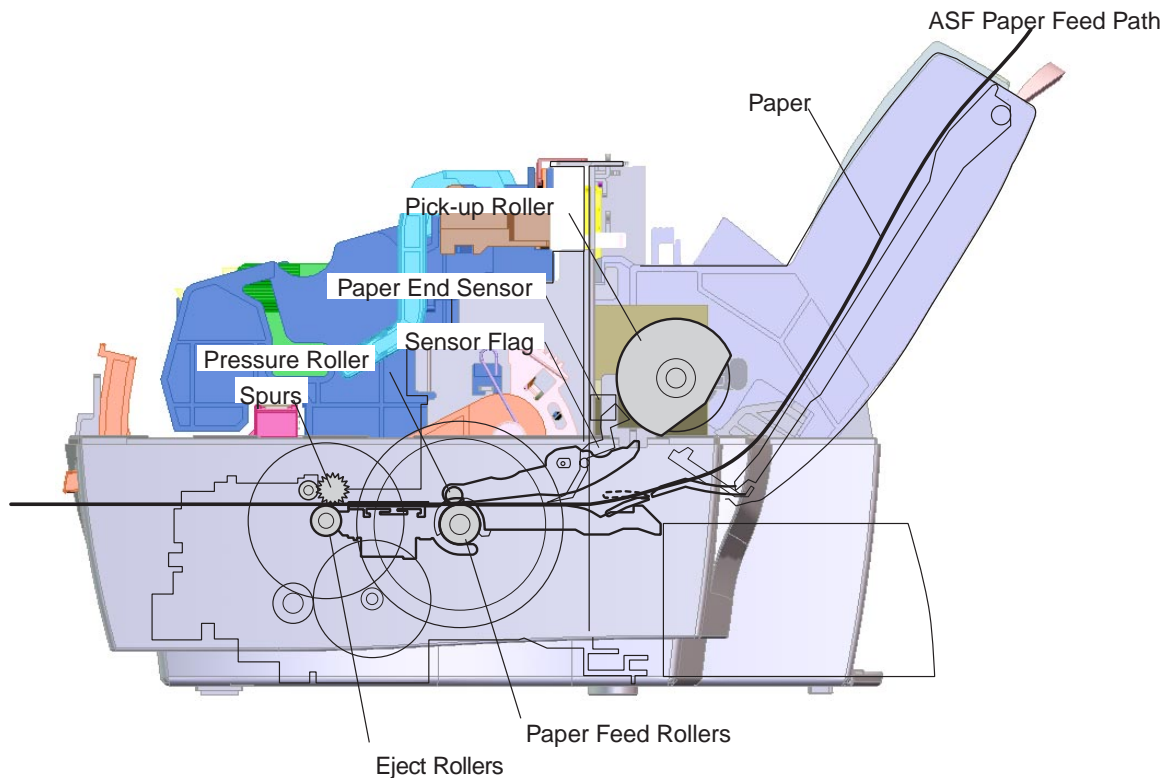

Figure 5-1 Paper Feed Path

1.2 Construction of the Paper Feed Unit

The BJC-6500's paper feed unit is comprised of the paper pick-up unit, paper feed unit, and the paper eject unit. Its' construction is different from that of the BJC-6100, as explained below.

a) Pick-up unit

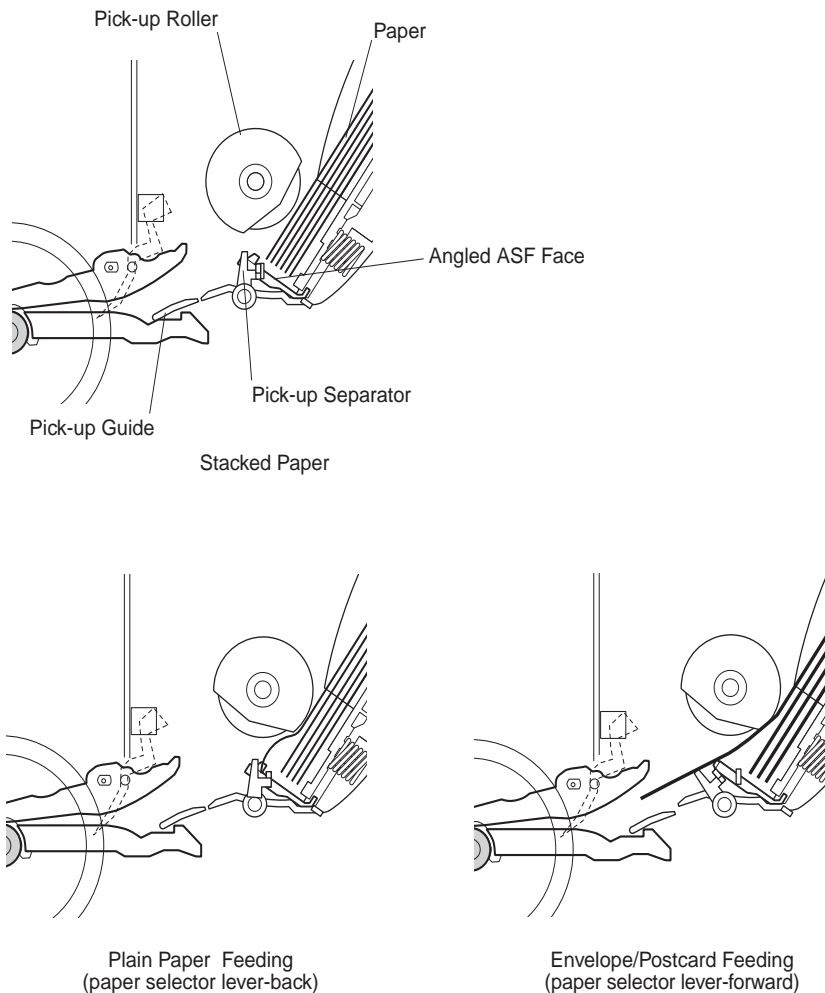

Figure 5-2 Paper Pick-up Unit

The pick-up unit of this printer is comprised of the pick-up roller, pick-up guide, the angled ASF face, and two pick-up separators.

The pick-up separators are connected to the paper selector lever, and depending on the position of the paper selector lever's setting, the pick-up separators can be raised or lowered.

When paper is stacked in the ASF, in order to prevent misfeeding due to bending of the paper, the angled face of the ASF is used to hold the paper in the place.

For print media such as plain paper, both corners of the media are held down by the pick-up separators, causing slight bending of the paper to separate the sheets, and the media is fed through to the paper feed rollers one sheet at a time.

If the paper is a resilient type, such as envelopes and thick paper, it pushes the paper separator over, and due to the angled face of the ASF, is fed one sheet at a time.

While this construction provides better feeding performance, if the paper selector lever is incorrectly positioned, misfeeding or multi-feeding can occur. For details, refer to *Part 1: 2.2.2 Paper type/settings (Page1-4)*

1.3 Form Alignment Function

In order to improve the paper feeding capability of the BJC-6500, such as reducing skew, the printer has a built-in form alignment function to detect the top of fed media.

The form alignment function allows paper to press against the paper feed roller to create a bend in the paper, and this bend forces the leading edge of the paper to become aligned to permit straight-line feeding. The form alignment function is not used, however, when printing in HS mode.

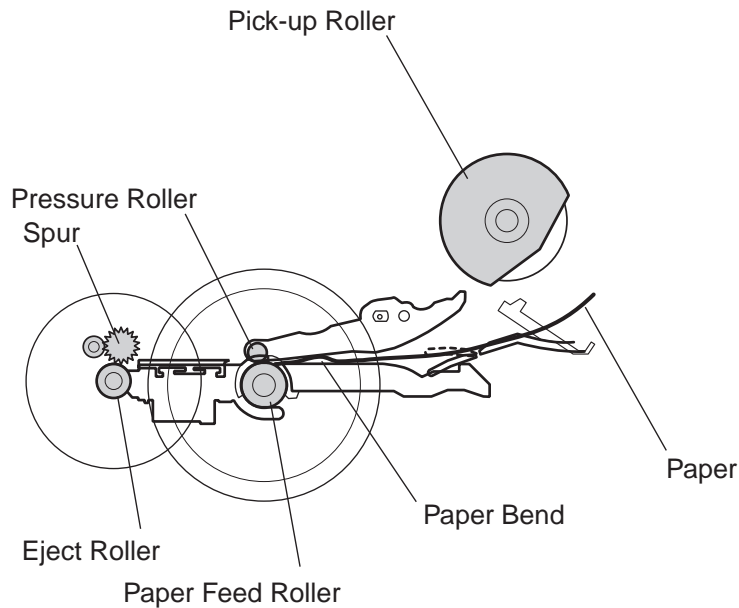

Figure 5-3 Form Alignment Function

```
ROM Ver Vx.xx BJC-6000 Use Head <BC-xx,BC-xx> HeadTemp0=xxx.x HeadTemp1=xxx.x EnvironmentTemp=xxx.x Bk=xxxxxxxx C1=xxxxxxxx Ph=xxxxxxxx
Factory Area=xx xx xx xx xx xx xx LostInkCount =xx.x% Destination =xx
```

Form Alignment Off

```
ROM Ver Vx.xx BJC-6000 Use Head <BC-xx,BC-xx> HeadTemp0=xxx.x HeadTemp1=xxx.x EnvironmentTemp=xxx.x Bk=xxxxxxxx C1=xxxxxxxx Ph=xxxxxxxx
Factory Area=xx xx xx xx xx xx xx LostInkCount =xx.x% Destination =xx
```

Form Alignment On

Figure 5-4 Form Alignment Function On/Off

REFERENCE

1.4 Transmission Gear Unit

Depending on the carriage position, the transmission gear unit switches the paper feed motor's drive power over to drive the purge unit or the auto-sheet feeder. The slide arm that moves with the carriage action controls the timing of the switching and the operation.

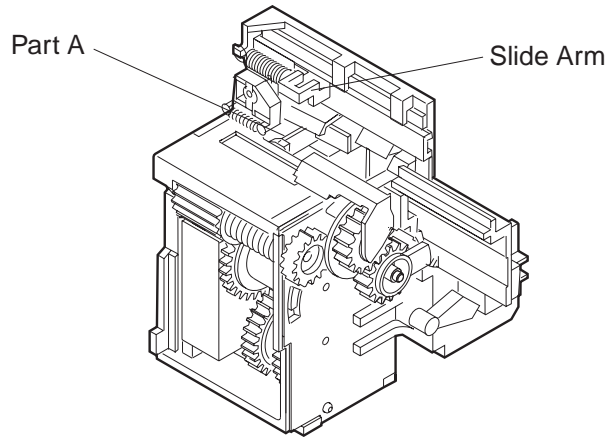

Figure 5-5 Drive Switching Unit

ASF drive occurs when the slide arm depresses part A. When this occurs, the internal rocker arm applies pressure to engage the ASF drive gears.

With the gears engaged, the ASF drive gears rotate, and ASF driving takes place. The ASF gear is controlled by a single rotation clutch, as in the BJC-6100, and after rotating one turn, rotation stops. With the single rotation clutch, when the carriage depresses part A once, the pick up roller can be rotated, allowing paper feeding to occur during printing. As a result, matching the phase of the ASF drive gear is necessary. For details, refer to *Part 2: 2.4.5 How to adjust the ASF gear position* (Page 2-14).

Purge driving occurs when the slide arm flag secures the switching flag in the purge drive position.

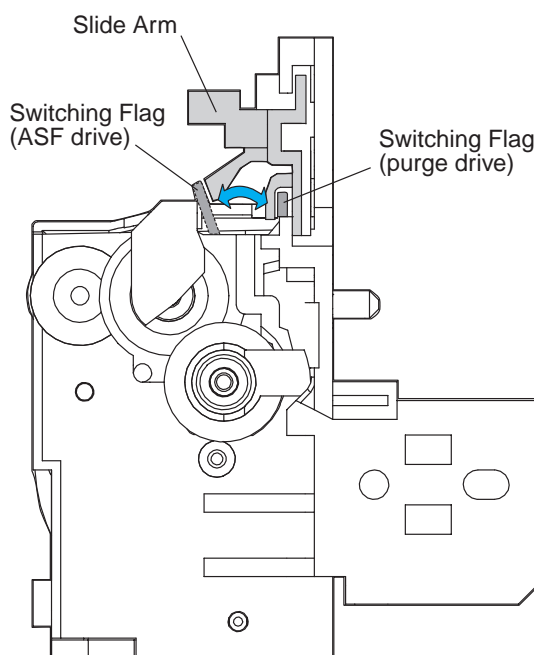

Figure 5-6 Operation of the Drive Switching Unit

1.5 Detection with Sensors

This printer has the following sensors to detect the printer's status.

In the BJC-6500, to more accurately detect the pick-up roller's position, a photo-interrupter type ASF sensor has been added.

With the ASF sensor, as the pick-up roller's position can be detected, incorrect pick-up roller position during initialization and paper pick-up operations can be detected.

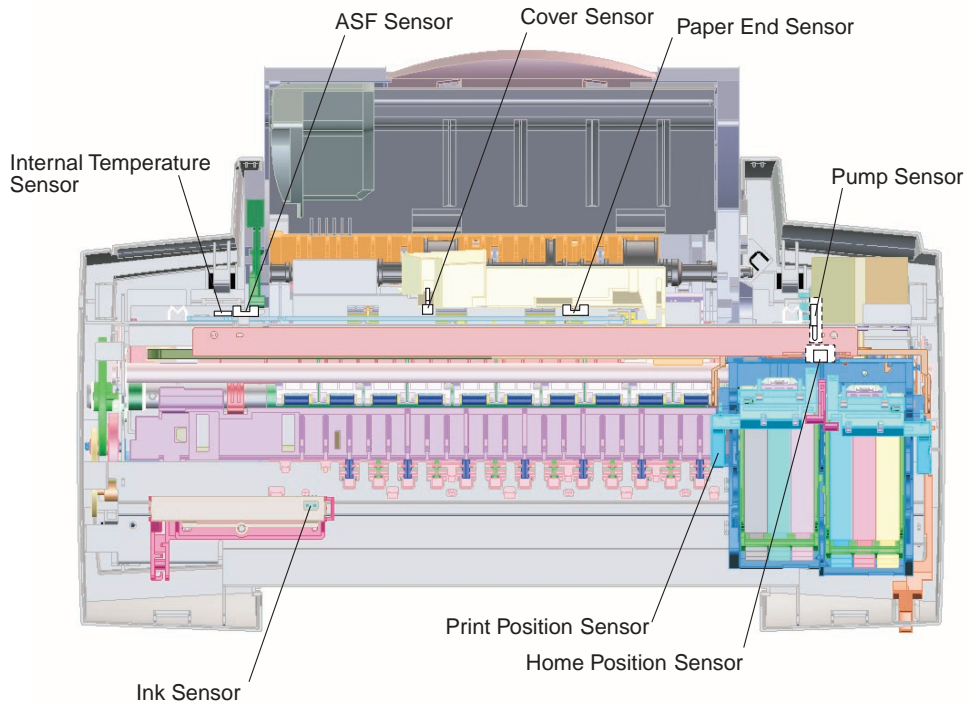

Figure 5-7 Sensor Positions

1.6 BJ Cartridge Identification

This printer determines whether a cartridge is installed or not by the resistance values of DIA (pin 30) and DIK (pin 31) on the signal contact pad. For example, if only 1 cartridge is installed, or if the scanner cartridge (recognized only in the left cartridge) is installed in the color cartridge (right) side, a "Cartridge not installed" error will occur.

When the printer determines that a cartridge is installed, serial communication through 6 signals (HCLK, pin 13; HDATA, pin 9; HRESET, pin 29; DIR, pin 28; HCHKR, pin 18; and HLAT, pin 19) is conducted, and the type of cartridge installed (Black, Color, Photo, or Scanner) is detected, along with its' head rank.

If the installed cartridges are not correctly matched, a "Cartridge Mis-installed" error will occur.

2. CONNECTOR POSITIONS AND PIN ASSIGNMENT

2.1 Control Board

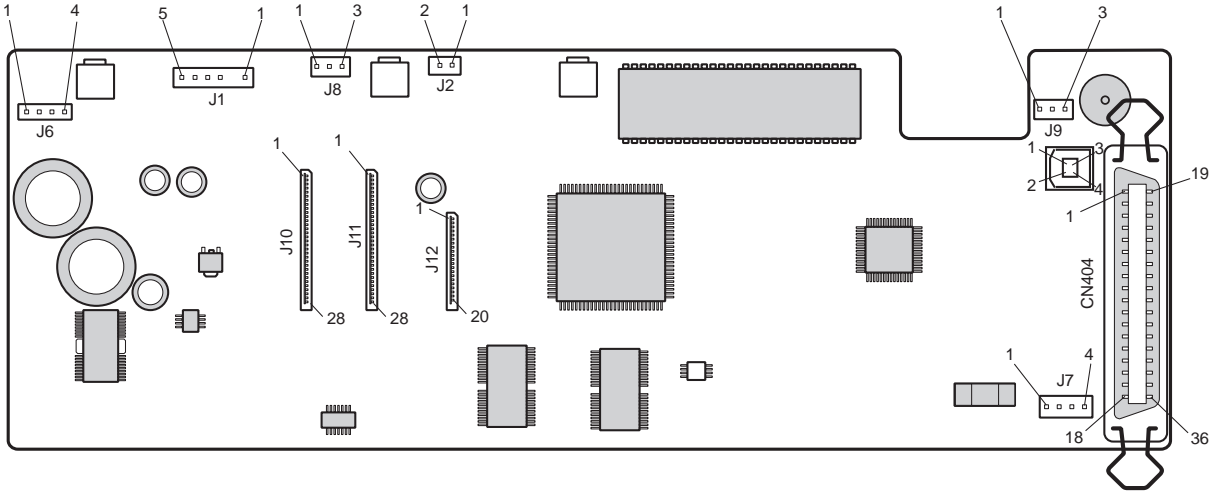

Figure 5-8 Control Board

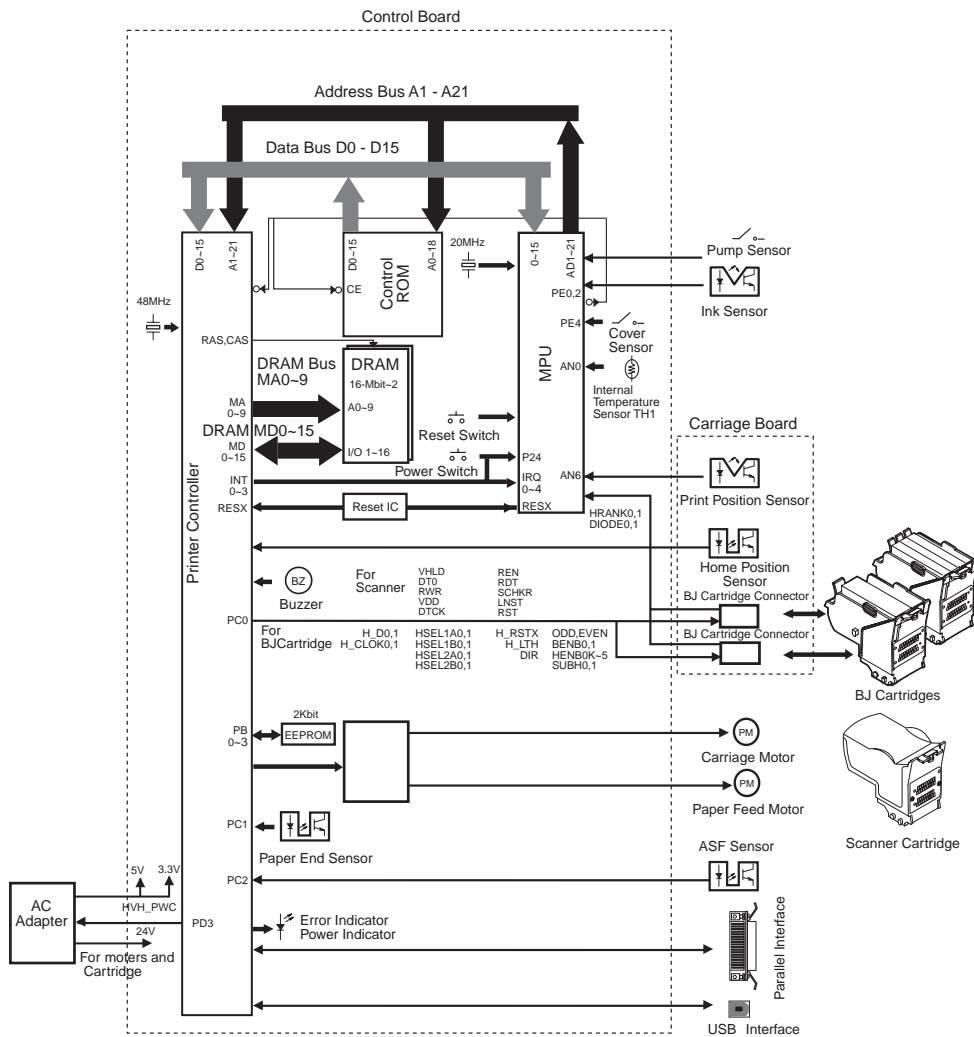

Figure 5-9 Block Diagram

J4 (Parallel interface connector)

Pin No.	Compatible Mode	Nibble Mode	ECP Mode
1	STROBE	HostClk	HostClk
2	DATA1	Data1	Data1
3	DATA2	Data2	Data2
4	DATA3	Data3	Data3
5	DATA4	Data4	Data4
6	DATA5	Data5	Data5
7	DATA6	Data6	Data6
8	DATA7	Data7	Data7
9	DATA8	Data8	Data8
10	ACKNLG	PrtClk	PeriphClk
11	BUSY	PrtBusy	PeriphAck
12	P.E.	AckDataReq	AckReverse
13	SELECT	Xflag	Xflag
14	AUTO FEED XT	HostBusy	HostAck
15	N.C	N.C.	N.C.
16	INIT	Gnd	Gnd
17	GND	Gnd	Gnd
18	+5.0V	Vcc	Vcc
19	STROBE-RET	Signal Gnd	Signal Gnd
20	DATA1-RET	Signal Gnd	Signal Gnd
21	DATA2-RET	Signal Gnd	Signal Gnd
22	DATA3-RET	Signal Gnd	Signal Gnd
23	DATA4-RET	Signal Gnd	Signal Gnd
24	DATA5-RET	Signal Gnd	Signal Gnd
25	DATA6-RET	Signal Gnd	Signal Gnd
26	DATA7-RET	Signal Gnd	Signal Gnd
27	DATA8-RET	Signal Gnd	Signal Gnd
28	ACKNLG-RET	Signal Gnd	Signal Gnd
29	BUSY-RET	Signal Gnd	Signal Gnd
30	P.E.-RET	Signal Gnd	Signal Gnd
31	INIT	INIT	ReverseReq
32	ERROR	DataAvail	PeriphReq
33	GND	N.C.	N.C.
34	N.C	N.C.	N.C.
35	+5.0V	N.C.	N.C.
36	SELECT IN	1284Active	1284Active

J5 (USB Interface connector)

Pin No.	Signal	IN/OUT	Function
1	PWR	IN	Cable power supply
2	D-	IN/OUT	Data
3	D+	IN/OUT	Data
4	GND	...	GND

J1 (DC power connector)

Pin No.	Signal	IN/OUT	Function
1	...	IN	+5V DC
2	HVCONT	OUT	+24V DC output control signal
3	GND	...	GND
4	...	IN	+24V DC
5	GND	...	GND

J6 (Carriage motor connector)

Pin No.	Signal	IN/OUT	Function
1	CRA	OUT	Carriage motor phase A
2	CRB	OUT	Carriage motor phase B
3	$\overline{\text{CRA}}$	OUT	Carriage motor phase A
4	$\overline{\text{CRB}}$	OUT	Carriage motor phase B

J7 (Paper feed motor connector)

Pin No.	Signal	IN/OUT	Function
1	LFA	OUT	Paper feed motor phase A
2	LFB	OUT	Paper feed motor phase B
3	$\overline{\text{LFA}}$	OUT	Paper feed motor phase $\overline{\text{A}}$
4	$\overline{\text{LFB}}$	OUT	Paper feed motor phase $\overline{\text{B}}$

J10 (Carriage ribbon cable connector)

Pin No.	Signal	IN/OUT	Function
1~10	HVH	OUT	Head drive voltage (VH)
11, 12, 13	SUBH0	OUT	Sub-heater drive voltage (for left cartridge)
14, 15, 16	SUBH1	OUT	Sub-heater drive voltage (for right cartridge)
17~26	Head drive voltage GND
27, 28	Head logic drive voltage GND

J11 (Carriage ribbon cable connector)

Pin No.	Signal	IN/OUT	Function
1	DIR	OUT	Serial data input/output direction control signal
2	HENB3	OUT	Front heater drive signal for nozzles 113-160
3	HENB2	OUT	Rear heater drive signal for nozzles 113-160
4	HENB1	OUT	Front heater drive signal for nozzles 1-112
5	HENB0	OUT	Rear heater drive signal for nozzles 1-112
6	BENB1	OUT	Signal to generate heater enable decoder outputs
7	BENB0	OUT	Signal to generate heater enable decoder outputs
8	EVEN	OUT	Even-number nozzles select signal
9	ODD	OUT	Odd-number nozzles select signal
10	HALT	OUT	Serial data latch timing signal
11	HRSTX	IN	Reset signal
13	HSEL2B0	OUT	Front nozzle heater select signal for lower nozzles (9-16, 25-32, ..., 153-160)
14	HSEL2A0	OUT	Rear nozzle heater select signal for lower nozzles (9-16, 25-32, ..., 153-160)
15	HSEL1B0	OUT	Front nozzle heater select signal for lower nozzles (9-16, 25-32, ..., 153-160)
16	HSEL1A0	OUT	Rear nozzle heater select signal for upper nozzles (1-8, 17-24, ..., 145-152)
12,17,19,21	LOGIC_GND	...	Logic GND
18	HCLOCK0	IN/OUT	Clock signal for serial data transmission
20	HDATA0	IN/OUT	Serial data (left cartridge) sent in sync. with the clock signal)
22	SENSOR_GND	...	Sensor GND
23	DIA0	IN	Head temperature (diode) sensor's anode line
24	DIAK	IN	Head temperature (diode) sensor's cathode line
25	HPA	OUT	Home position sensor pull-up voltage
26	HPC	IN	Home position sensor sense signal
27	REGA	OUT	Print position sensor's LED drive voltage
28	REGC	IN	Voltage input from the print position sensor

J12 (Carriage ribbon cable connector)

Pin No.	Signal	IN/OUT	Function
1	HSEL2B1	OUT	Front nozzle heater select signal for lower nozzles (9-16, 25-32, ..., 153-160)
2	HSEL2A1	OUT	Rear nozzle heater select signal for lower nozzles (9-16, 25-32, ..., 153-160)
3	HSEL1B1	OUT	Front nozzle heater select signal for lower nozzles (9-16, 25-32, ..., 153-160)
4	HSEL1A1	OUT	Rear nozzle heater select signal for upper nozzles (1-8, 17-24, ..., 145-152)
5,7,9,12,13,17	LGND	...	Head logic voltage GND
6	HCLOCK1	IN/OUT	Clock signal for serial data transmission
8	HDATA1	IN/OUT	Serial data (right cartridge) sent in sync. with the clock signal)
10	HENB5	OUT	Front heater drive signal for nozzles 1-160
11	HENB4	OUT	Rear heater drive signal for nozzles 1-160
14	SNSG	...	GND
15	DIA1	IN	Head temperature (diode) sensor's anode line
16	DIK1	IN	Head temperature (diode) sensor's cathode line
18,19,20	HVDD	OUT	Head logic drive voltage

J2 (Pump sensor connector)

Pin No.	Signal	IN/OUT	Function
1	POMP	IN	Pump sensor sense signal High (sense) /Low
2	GND

J8 (Ink sensor connector)

Pin No.	Signal	IN/OUT	Function
1	INKS01	OUT	Ink sensor's LED drive signal
2	GND
3	INKS	IN	Voltage output from the ink sensor

J9 (Paper end sensor connector)

Pin No.	Signal	IN/OUT	Function
1	...	OUT	Paper end sensor's internal drive voltage diode
2	GND
3	INKS	IN	Paper end sensor signal low (paper present)/High (5V)

2.2 Carriage Board

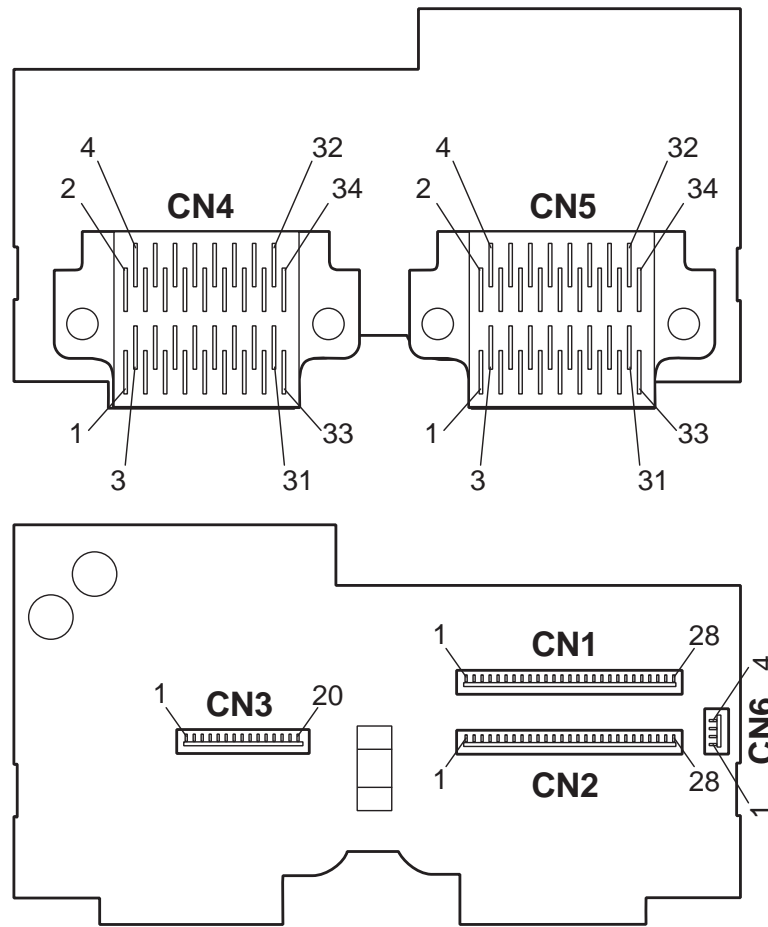

Figure 5-10 Carriage Board

CN1 (Carriage ribbon cable connector)

Pin No.	Signal	IN/OUT	Function
1, 2	LGND	...	GND for logic power supply
3~12	HGND	...	GND for head drive voltage (VH)
13, 14, 15	SUBH1	IN	Sub-heater drive voltage (for right cartridge)
16, 17, 18	SUBH0	IN	Sub-heater drive voltage (for left cartridge)
19~28	HVH	IN	Head drive voltage (VH)

REFERENCE

CN2 (Carriage ribbon cable connector)

Pin No.	Signal	IN/OUT	Function
1	REGC	OUT	Voltage output from the print position sensor
2	REGA	IN	Print position sensor's LED drive voltage
3	HPC	OUT	Home position sensor sense signal
4	HPA	IN	Home position sensor pull-up voltage
5	DIK0	OUT	Head temperature (diode) sensor's cathode line
6	DIA0	OUT	Head temperature (diode) sensor's anode line
7	SNSG	...	GND
8,10,12,17	LGND	IN	GND for the logic power supply
9	HDATA0	OUT	Serial data (for right carriage) sent in synchronization with the clock signal
11	HCLOCK0	IN/OUT	Clock signal for serial data transmission
13	HSEL1A0	IN	Front nozzle heater select signal for upper nozzles (1-8, 17-24, ..., 145-152)
14	HSEL1B0	IN	Rear nozzle heater select signal for upper nozzles (1-8, 17-24, ..., 145-152)
15	HSEL2A0	IN	Front nozzle heater select signal for lower nozzles (9-16, 25-32, ..., 153-160)
16	HSEL2B0	IN	Rear nozzle heater select signal for lower nozzles (9-16, 25-32, ..., 153-160)
18	HRSTX	IN	Reset signal
19	HALT	IN	Serial data latch timing signal
20	ODD	IN	Odd-number nozzles select signal
21	EVEN	IN	Even-number nozzles select signal
22	BENB0	IN	Signal to generate heater enable decoder outputs
23	BENB1	IN	Signal to generate heater enable decoder outputs
24	HENB0	IN	Rear heater drive signal for nozzles 1-112
25	HENB1	IN	Front heater drive signal for nozzles 1-112
26	HENB2	IN	Rear heater drive signal for nozzles 113-160
27	HENB3	IN	Front heater drive signal for nozzles 113-160
28	DIR	IN	Serial data input/output direction control signal

CN3 (Carriage ribbon cable connector)

Pin No.	Signal	IN/OUT	Function
1, 2, 3	HVDD	OUT	Head logic voltage
4,8,9,12,14,16	LGND	...	GND
5	DIK1	IN	Head temperature (diode) sensor's cathode line
6	DIA1	IN	Head temperature (diode) sensor's anode line
7	SNSG	...	GND
10	HENB4	IN	Rear heater drive signal for nozzles 1-160
11	HENB5	IN	Front heater drive signal for nozzles 1-160
13	HDATA1	OUT	Serial data (for right cartridge) sent in synchronization with the clock signal
15	HCLOCK1	IN/OUT	Clock signal for serial data transmission
17	HSEL1A1	OUT	Front nozzle heater select signal for upper nozzles (1-8, 17-24, ..., 145-152)
18	HSEL1B1	OUT	Rear nozzle heater select signal for upper nozzles (1-8, 17-24, ..., 145-152)
19	HSEL2A1	OUT	Front nozzle heater select signal for lower nozzles (9-16, 25-32, ..., 153-160)
20	HSEL2B1	OUT	Rear nozzle heater select signal for lower nozzles (9-16, 25-32, ..., 153-160)

CN4 (BJ cartridge, left)

Pin No.	Signal	IN/OUT	Function
1~32			Refer to Page 5-14 (Reverse of signal's IN/OUT)
33, 34	N.C.

CN5 (BJ cartridge, right)

Pin No.	Signal	IN/OUT	Function
1~32			Refer to Page 5-14 (Reverse of signal's IN/OUT)
33, 34	N.C.

CN6 (Print position sensor connector)

Pin No.	Signal	IN/OUT	Function
1	REGA	IN	Print position sensor's LED drive voltage
2	SNSG	...	GND
3	REGC	IN	Voltage input from the print position sensor
4	LGND	...	GND

2.3 BJ Cartridge

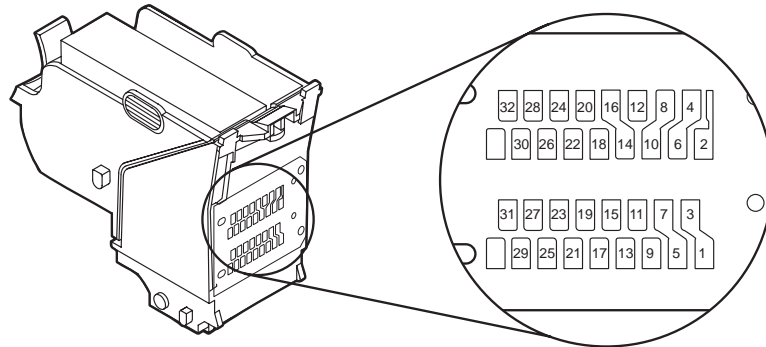

Figure 5-11 BJ Cartridge

Pin No.	Signal	IN/OUT	Function
1, 2, 3	HVH	OUT	Head drive voltage (VH)
4, 6	SUBH0 (SUBH1)	OUT	Sub-heater drive signal
5, 7, 8, 10	VHG	...	GND for Head drive voltage (VHGND)
9	HDATA0 (HDATA1)	IN/OUT	Serial data (including head identification and rank resistance) sent in sync. with the clock signal (H_CLK)
11	HSEL1B0 (HSEL1B1)	OUT	Rear nozzle heater select signal for upper nozzles (1-8, 17-24, ..., 145-152)
12	HVDD	OUT	Head logic drive voltage (+5 V)
13	HCLOCK0 (HCLOCK1)	IN/OUT	Clock signal for serial data transmission
14, 16	LGND	OUT	GND for head logic drive voltage (HVDD)
15	HSEL1A0 (HSEL1A1)	OUT	Front nozzle heater select signal for upper nozzles (1-8, 17-24, ..., 145-152)
17	HSEL2A0 (HSEL2A1)	OUT	Front nozzle heater select signal for lower nozzles (9-16, 25-32, ..., 153-160)
18	HSEL2B0 (HSEL2B1)	OUT	Rear nozzle heater select signal for lower nozzles (9-16, 25-32, ..., 153-160)
19	HLAH	OUT	Serial data latch timing signal
20	ODD	OUT	Odd-number nozzles select signal
21	EVEN	OUT	Even-number nozzles select signal
22	BENB0	OUT	Signal to generate heater enable decoder outputs
23	BENB1	OUT	Signal to generate heater enable decoder outputs
24	HENB0 (HENB4)	OUT	Rear heater drive signal for nozzles 1-112 (or 1-144)
25	HENB1 (HENB5)	OUT	Front heater drive signal for nozzles 1-112 (or 1-144)
26	HENB2 (HENB4)	OUT	Front heater drive signal for nozzles 1-112 (or 1-144)
27	HENB3 (HENB5)	OUT	Front heater drive signal for nozzles 1-112 (or 1-144)
28	DIR	OUT	Front heater drive signal for nozzles 113-160
29	HRSTX	OUT	Serial data input/output direction control signal Reset signal
30	DIA0 (DIA1)	IN	Head temperature (diode) sensor's anode line
31	DIK0 (DIK1)	IN	Head temperature (diode) sensor's cathode line
32	N.C.

2.4 Scanner Cartridge (Optional)

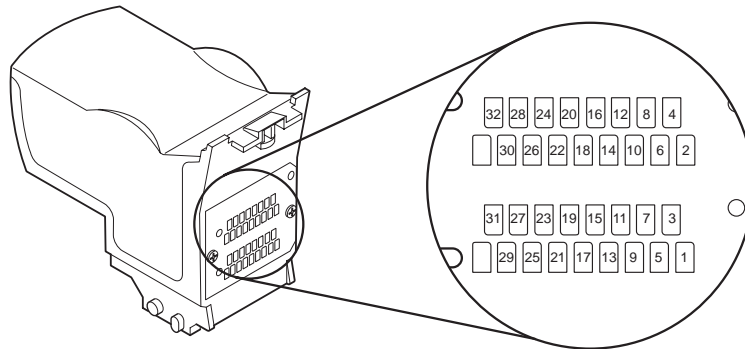

Figure 5-12 Scanner Cartridge

Pin No.	Signal	IN/OUT	Function
1, 2, 3	VHLED	IN	+24V, for LED
4	N.C.	...	Not used
5	GNDLED	...	GND
6	N.C.	...	Not used
7, 8	GNDLED	...	GND
9	DTO	IN/OUT	Serial data of scanned images
10	GNDLED	...	GND
11	RWR	IN	Right clock for internal register setting
12	VDD	IN	+5V
13	DTCK	IN/OUT	Serial data clock of scanned images
14	VSS	...	GND
15	REN	IN	Enable signal for internal register setting
16	VSS	...	GND
17	RDT	IN	Internal register setup data
18	SCHKR	IN	Scanner cartridge detection and recognition
19	LNST	IN	Scan start signal (1 line scan)
20, 21, 22	N.C.	IN	Not used
23	DT1	IN	Factory
24	DT2	IN	Factory
25	DT3	IN	Factory
26, 27, 28	N.C.	IN	Not used
29	RST	IN	Reset
30	DIA	OUT	Scanner cartridge detection and recognition
31	DIK	OUT	Scanner cartridge detection and recognition
32	Not used

2.5 AC Adapter

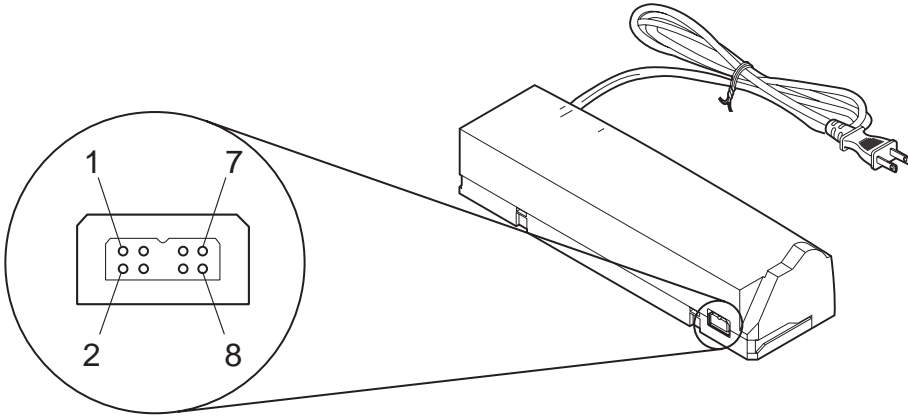

Figure 5-13 AC Adapter

Pin No.	Signal	IN/OUT	Function
1	N.C
2	N.C
3	+24V DC
4	GND	...	GND
5	...	OUT	+5V DC
6	N.C
7	HVCONT	IN	+24V control signal
8	GND	...	GND

2.6 DC Power Supply Cable

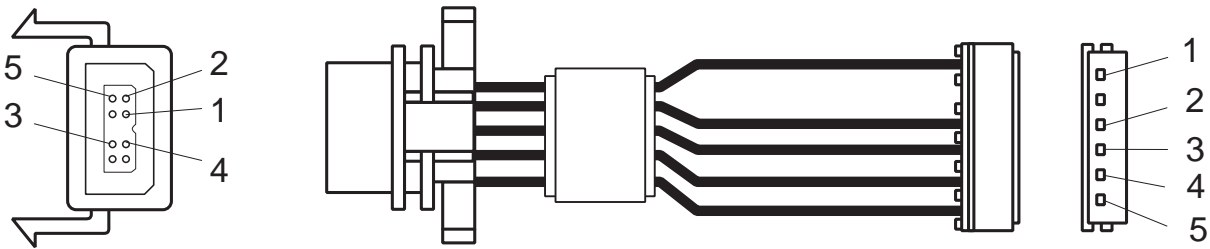

Figure 5-14 DC Power Supply Cable

Pin No.	Signal	IN/OUT	Function
1	...	OUT	+5V DC
2	HVCONT	IN	+24V DC output control signal
3	GND	...	GND
4	...	OUT	+24V DC
5	GND	...	GND

2.7 Carriage Motor

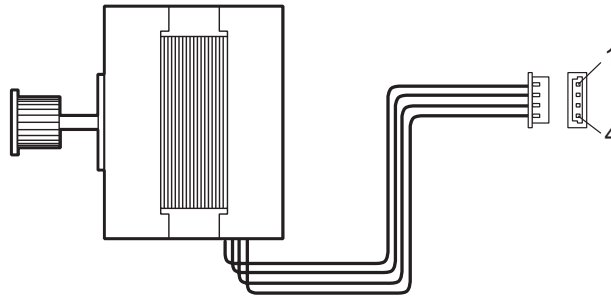

Figure 5-15 Carriage Motor

Pin No.	Signal	IN/OUT	Function
1	CRA	IN	Carriage motor phase A
2	CRB	IN	Carriage motor phase B
3	$\overline{\text{CRA}}$	IN	Carriage motor phase $\overline{\text{A}}$
4	$\overline{\text{CRB}}$	IN	Carriage motor phase $\overline{\text{B}}$

2.8 Paper Feed Motor

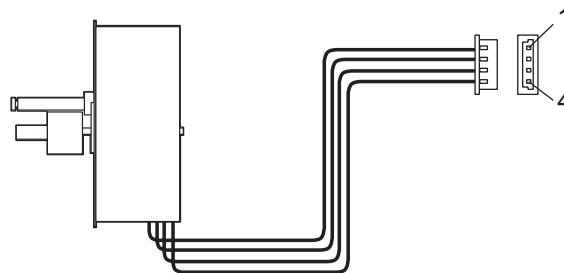

Figure 5-16 Paper Feed Motor

Pin No.	Signal	IN/OUT	Function
1	LFA	IN	Paper feed motor phase A
2	LFB	IN	Paper feed motor phase B
3	$\overline{\text{LFA}}$	IN	Paper feed motor phase $\overline{\text{A}}$
4	$\overline{\text{LFB}}$	IN	Paper feed motor phase $\overline{\text{B}}$

2.9 Paper End Sensor

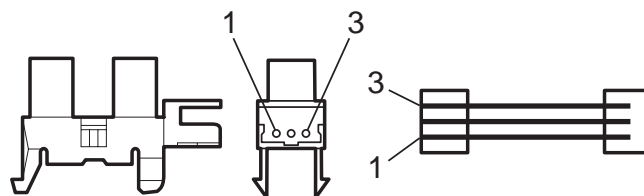

Figure 5-17 Paper End Sensor

Pin No.	Signal	IN/OUT	Function
1	...	OUT	Paper end sensor diode drive voltage
2	GND
3	INKS	IN	Paper end sensor signal Low (paper)/High (5V)

REFERENCE

2.10 Ink Sensor

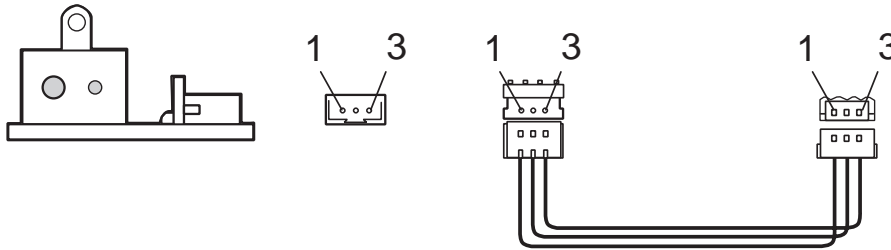

Figure 5-18 Ink Sensor

Pin No.	Signal	IN/OUT	Function
1	INKS01	OUT	Voltage output from the ink sensor
2	GND
3	N.C.

2.11 Print Position Sensor

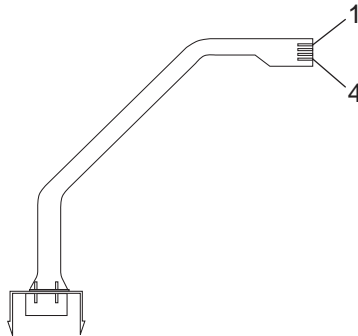

Figure 5-19 Print Position Sensor

Pin No.	Signal	IN/OUT	Function
1	REGA	OUT	Print position sensor's LED drive voltage
2	SNSG	...	GND
3	REGC	OUT	Voltage output from the print position sensor
4	LGND	...	GND

2.12 Pump Sensor

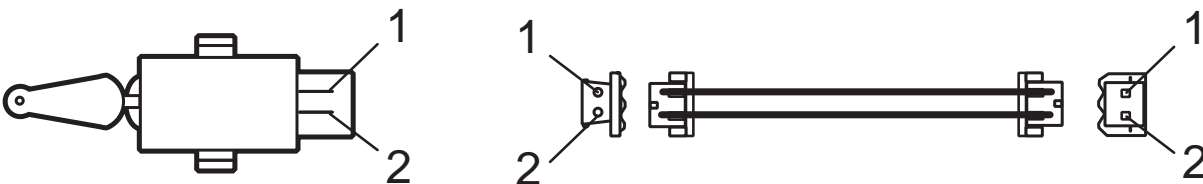

Figure 5-20 Pump Sensor

Pin No.	Signal	IN/OUT	Function
1	POMP	OUT	Pump sensor's sense signal High (sense) /Low
2	GND

3. INSTALLATION

3.1 Installation

For detailed procedures, refer to the User's Manual.

3.1.1 Installation location

To ensure optimum performance, install the printer where there is adequate space. The figure below illustrates the printer's outside dimensions.

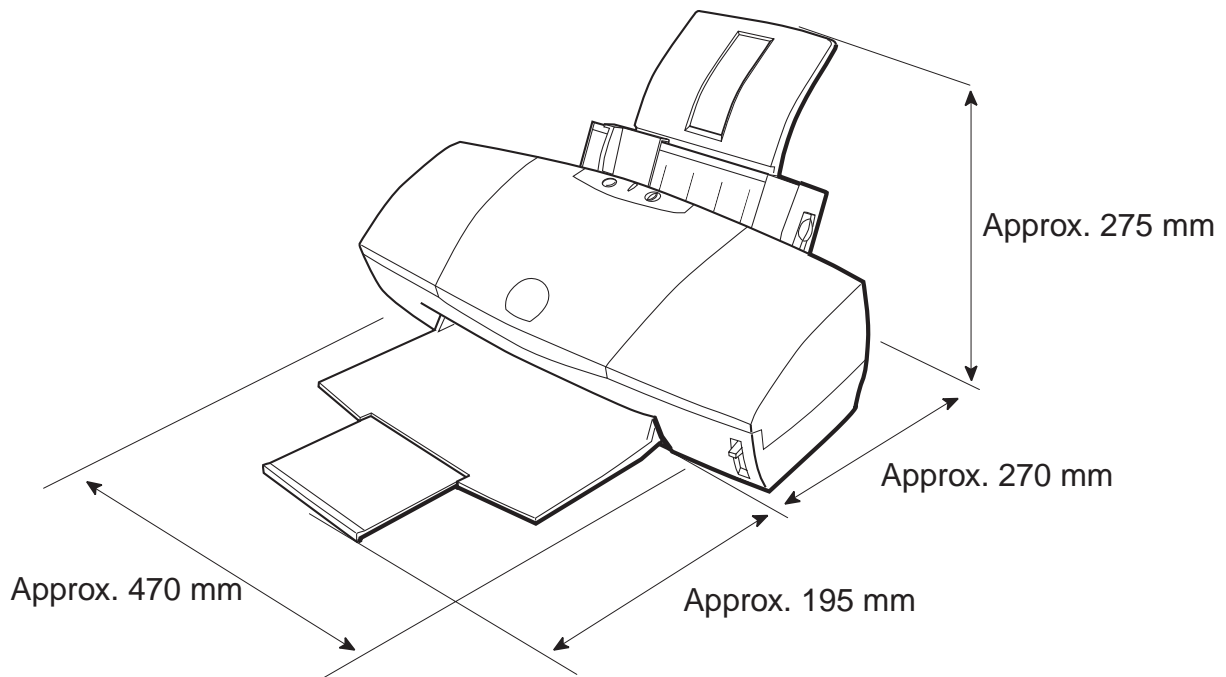

Figure 5-21 Printer Dimensions

3.2 Installation Procedures

To avoid problems regarding electrical differences between the computer and the printer, after connecting the interface cable, connect the plug of the power cord to an electrical outlet.

3.2.1 Connecting the interface cable

- 1) Make sure both the printer and the computer are switched OFF.
- 2) Connect the interface cable to the interface connector on the printer. Lock the connector clips.
- 3) Connect the other end of the interface cable to the computer, and lock into place.

3.2.2 Connecting the power supply

- 1) Connect the plug of the power cord to a wall outlet.
- 2) Press the printer's POWER button. The beeper sounds once and the indicator blinks in green indicating that the printer is in the initialization process. After initialization, the indicator lights in green. If BJ cartridges are not installed, the indicator lights in orange, the beeper sounds six times, and the carriage moves to the cartridge replacement position.

4. MISCELLANEOUS

4.1 Similarities and Differences to the BJC-6100

Unit	Compatibility	Comment
Mechanical		
Externals	×	Removable; standard paper output tray
Auto Sheet Feeder (ASF)	×	BJC-6500: A3 format; added the paper selector lever and ASF sensor BJC-6100: A4 format; no paper selector lever and ASF sensor
ASF drive switching	×	BJC-6500 : Form alignment function installed (improved paper feeding performance) BJC-6100 : No form alignment function
Platen	×	
Carriage	○	Extended flexible cable; different carriage board
LF roller	○	
Purge Unit	◎	
Electrical		
Motors	○	Extended carriage motor cable
Control board	○	Increased memory from 2MB to 4MB Different connector/pin array; addition of ASF sensor
Carriage board	○	Different pin array
Ink sensor	◎	
AC adapter	◎	
Heads		
BJ cartridges	◎	BC-30 (Black) / 31 (Color) / 32 (Photo)
Scanner	◎	IS-32
Software		
ROM	×	Addition of the form alignment function

Note:

- ◎: Complete compatibility (at the parts level; identical part number)
- : Partial compatibility (nearly identical in composition; different part number)
- ×: New (newly specified for the BJC-6500)

**** USING NUMBERS ****
 C1-C7
 C101-C111
 C201-C203
 C301-C302
 CA1-CA5
 CP1-CP3
 D1
 FB1-FB9 FB11-FB13
 FBA1-FBA4
 FU1
 IC1-IC4
 J1-J5
 JNT1
 LF1
 Q1-Q3
 R1-R21
 RA1-RA12
 SW1-SW3
 TH1
 X1
 ZD1
 ZDA1

C1xx are bi-pass for 3.3V
 C2xx are bi-pass for 5.0V
 C3xx are bi-pass for 24.0V

R 1/16W is 1608
 R 1/10W is 2125
 R 1/4W is 3216
 R 1/2W is 3225

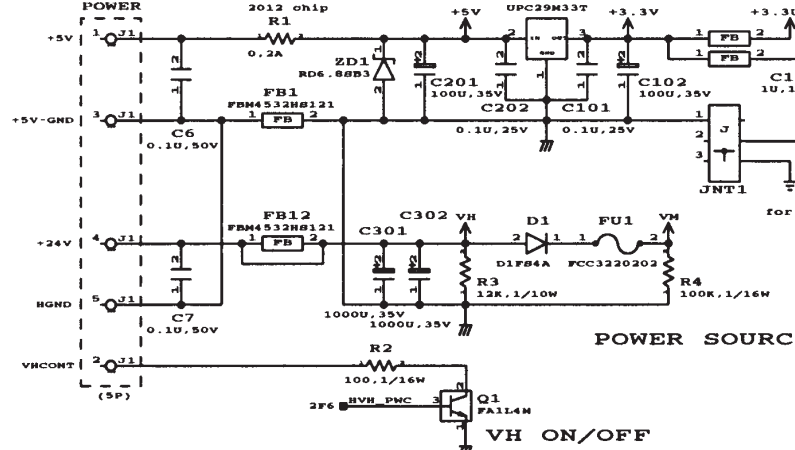
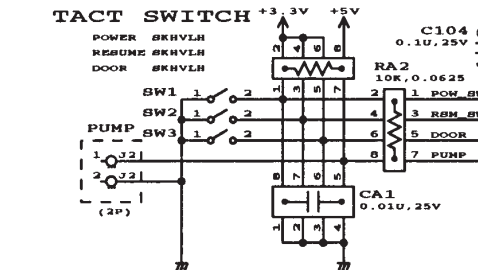
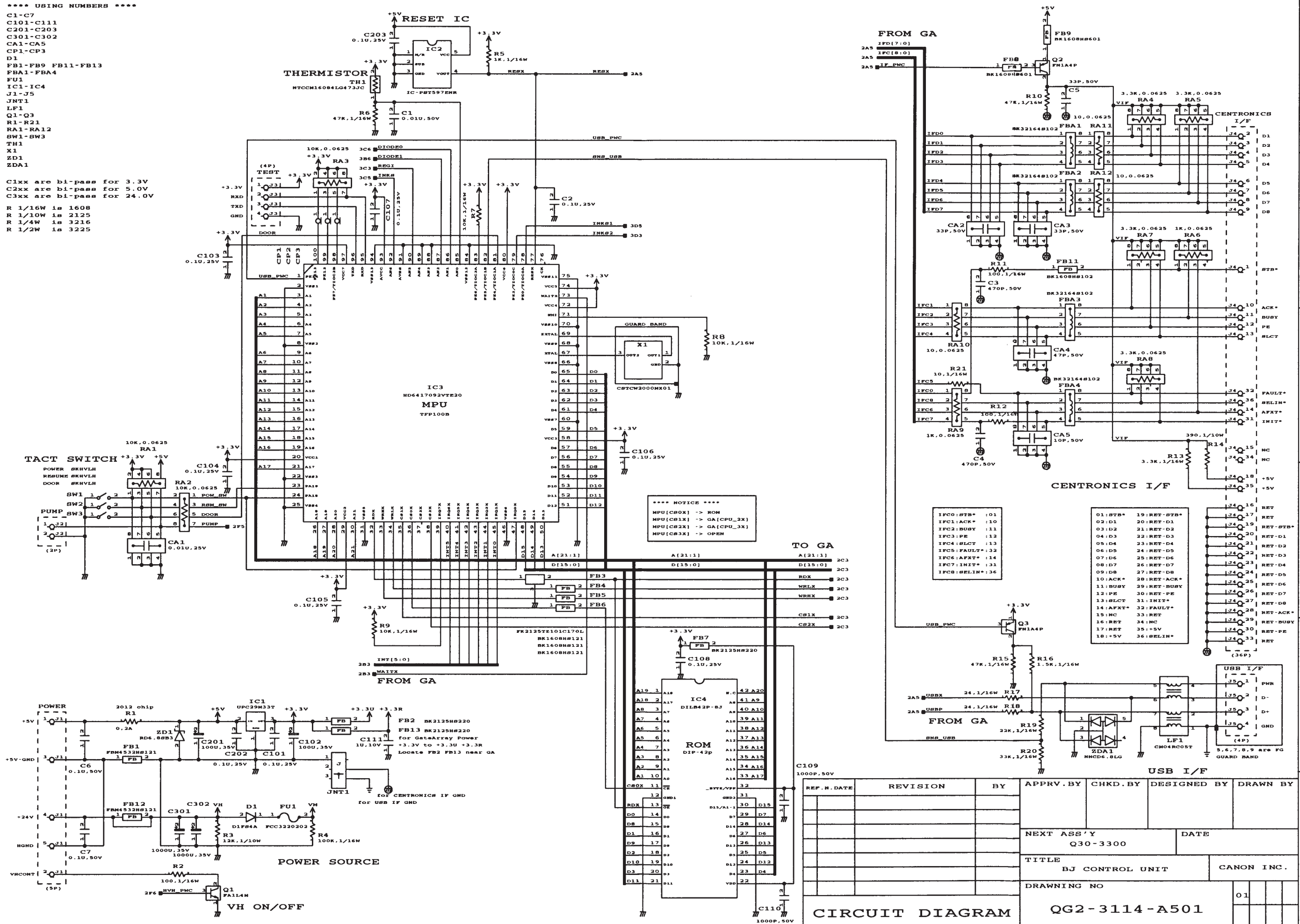

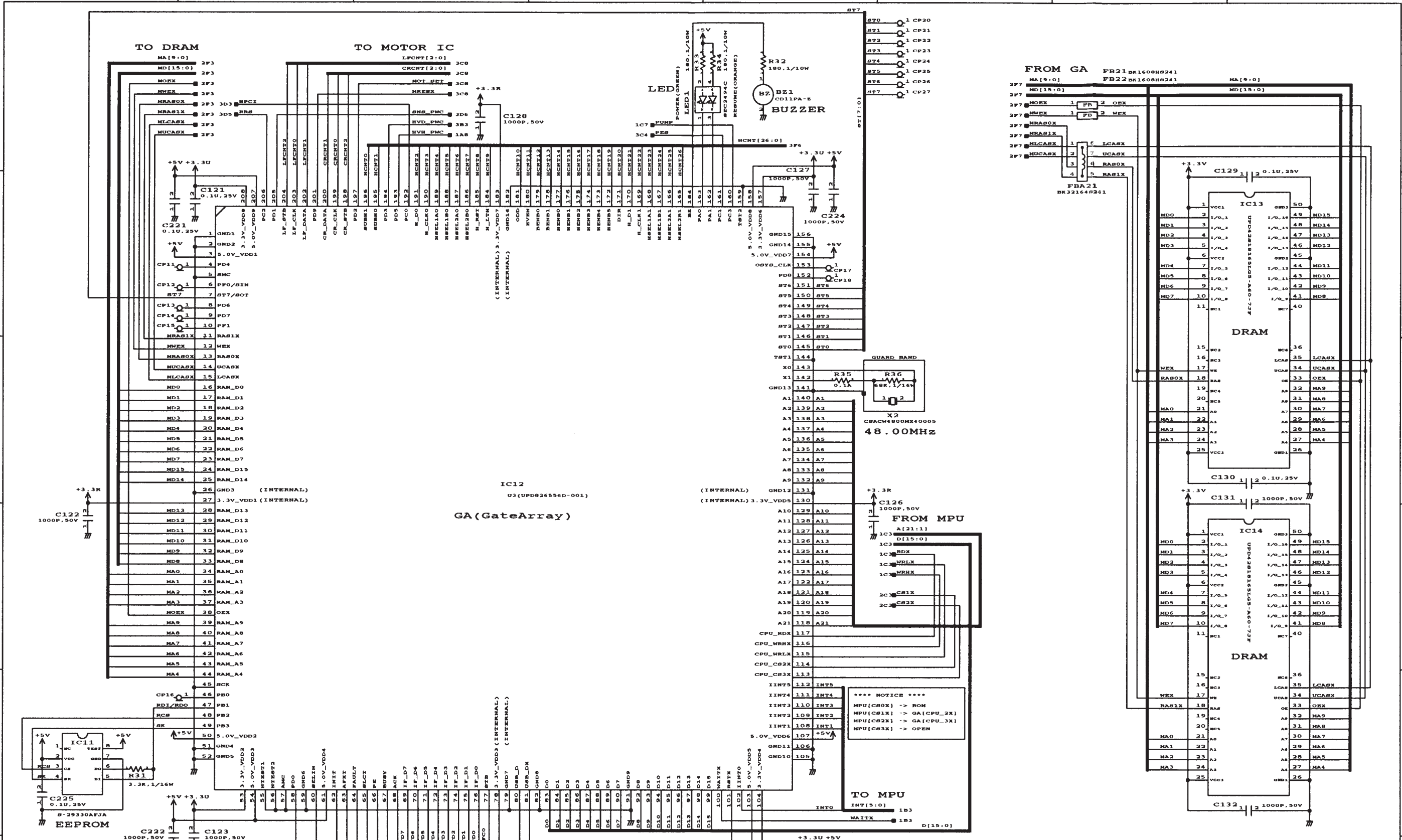

**** USING NUMBERS ****
 BZ1 IC11-IC14
 C21 LED1
 C121-C132 R31-R36
 C221-C225 X2
 CP11-CP18
 CP20-CP27
 FB21-FB22
 FBA21
 C1xx are bi-pass for 3.3V
 C2xx are bi-pass for 5.0V
 C3xx are bi-pass for 24.0V
 R 1/16W is 1608
 R 1/10W is 2125
 R 1/4W is 3216
 R 1/2W is 3225

**** NOTICE ****
 MPU[CS0X] -> ROM
 MPU[CS1X] -> GA[CPU_2X]
 MPU[CS2X] -> GA[CPU_3X]
 MPU[CS3X] -> OPEN

REF. N. DATE	REVISION	BY	APPRV. BY	CHKD. BY	DESIGNED BY	DRAWN BY
NEXT ASS'Y					DATE	
Q30-3300						
TITLE					CANON INC.	
BJ CONTROL UNIT						
DRAWING NO					01	
CIRCUIT DIAGRAM					QG2-3114-A502	



The printing paper contains
70% waste paper.

Canon